



# 8-Channel All-Ways-On™ Constant Current LED Driver

## Features

- Maximum 50V output sustaining voltage
- 8 constant-current output channels
- Adjustable 5 - 60mA output current per channel through an external resistor
- Constant output current invariant to load voltage change
- Excellent output current accuracy:  
between channels:  $< \pm 3\%$  (max.), and  
between ICs:  $< \pm 6\%$  (max.)
- Open-circuit detection mode to detect LED errors
- Integrated voltage regulator for 8 - 40V supply voltage
- Voltage feedback for DC/DC controller
- Package Type: "Pb-free & Green" package with thermal pad

Current Accuracy		Conditions
Between Channels	Between ICs	
$< \pm 3\%$	$< \pm 6\%$	$I_{OUT} = 5 \sim 60\text{mA}$

### Thin Shrink SOP

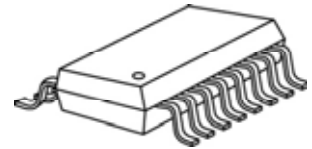

GTS: TSSOP16-173-0.65

### Quad Flat No-Lead

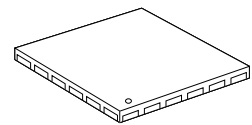

GFN: QFN24-4\*4-0.5

## Product Description

MBI1828 is an instant On/Off LED driver for lighting applications and exploits PrecisionDrive™ technology to enhance its output characteristics. At MBI1828 output stage, 8 regulated current ports are designed to provide uniform and constant current sinks for driving LEDs within a large range of  $V_F$  variations.

MBI1828 provides users 8-channel constant current ports to match LEDs with equal current. Users may adjust the output current from 5mA to 60mA through an external resistor,  $R_{ext}$ , which gives users flexibility in controlling the light intensity of LEDs. In addition, users can precisely adjust LED brightness from 0% to 100% via output enable (OE) with Pulse Width Modulation.

Additionally, to ensure the system reliability, MBI1828 is built with thermal pad which enhances the heat dissipation.

## Applications

- Automotive lighting
- Channel letter
- Decorative LED lighting
- LCD monitor

Functional Diagram

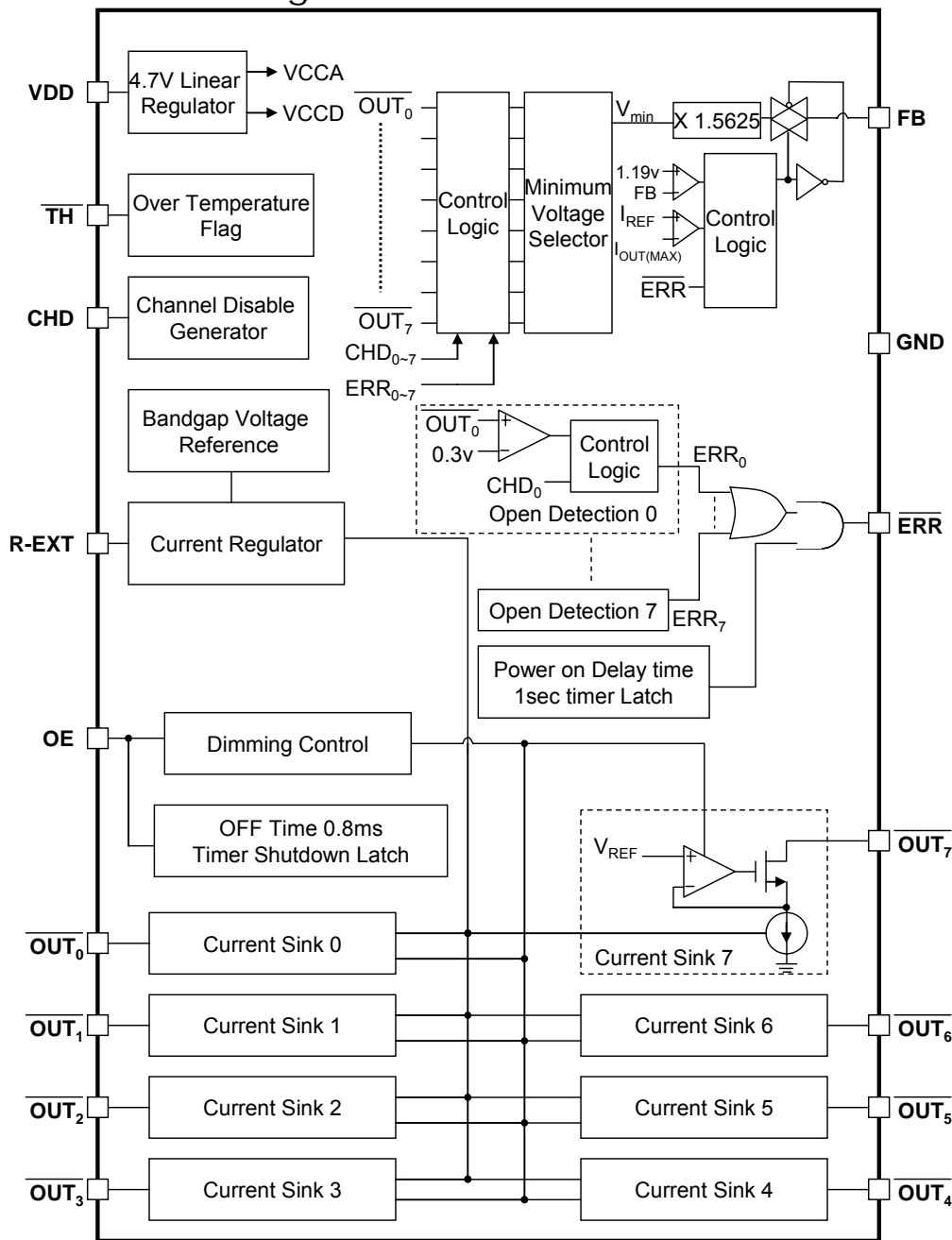
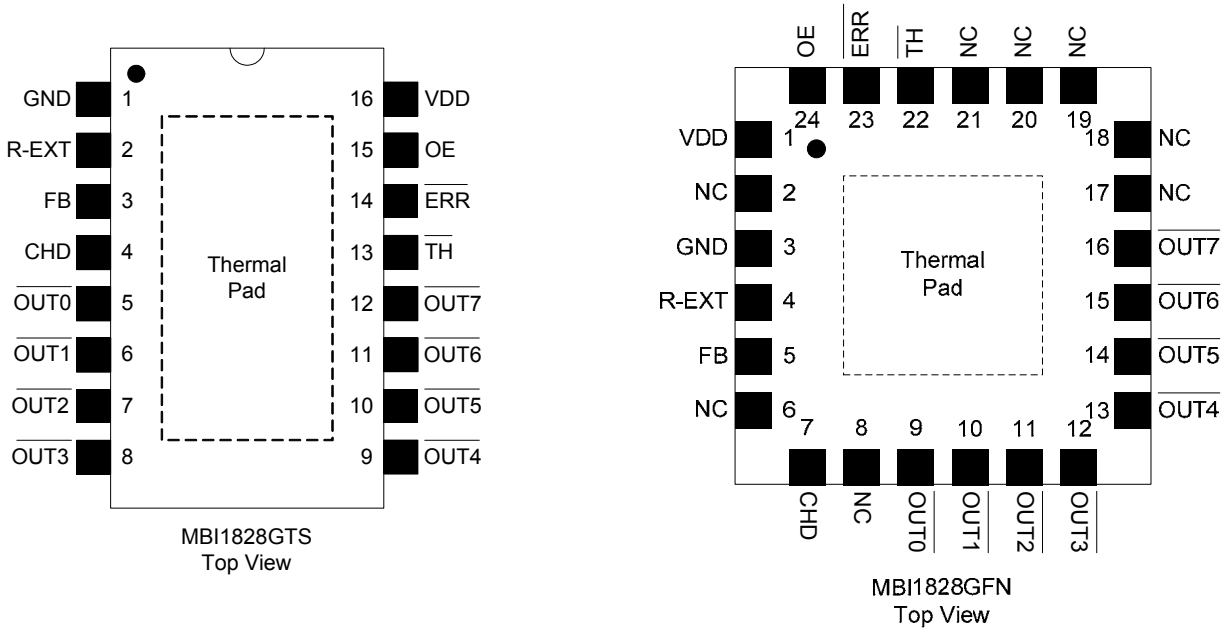

Figure 1

Pin Configuration



Pin Description

Pin No.		Pin Name	Function
GTS	GFN		
16	1	VDD	8V~40V Supply voltage terminal
1	3	GND*	Ground terminal for control logic and current sink
5-12	9-16	$\overline{\text{OUT0}} \sim \overline{\text{OUT7}}$	Constant current output terminals
15	24	OE	Output enable terminal When OE is active (high), the output pins are enabled; when OE is inactive (low), all output pins are turned off (blanked).
14	23	$\overline{\text{ERR}}$	Error Flag When any single output channel is open, $\overline{\text{ERR}}$ is going to low.
2	4	R-EXT	The terminal used to connect an external resistor for setting up output current for output channel
13	22	$\overline{\text{TH}}$	Thermal Flag When junction temperature is over 155 °C, $\overline{\text{TH}}$ is going to low.
4	7	CHD	Channel disable terminal. Non-used channels can be connected to the port for preventing wrong open-circuit detection result.
3	5	FB	Feedback control voltage to DC/DC controller. The relationship between FB and minimum output voltage is $V_{FB}=1.56 \times \text{minimum output voltage}(V_{DS, \text{min}})$
-	-	Thermal Pad	Power dissipation terminal*
-	2, 6, 8, 17-21	NC	No Connection

\*The desired thermal conductivity will be improved on condition that a heat-conducting copper foil on PCB is soldered with thermal pad.

Maximum Ratings

Characteristic		Symbol	Rating	Unit
Supply Voltage		$V_{DD}$	42	V
Sustaining Voltage at OE		$V_{IN}$	$-0.4 \sim V_{DD} + 0.4$	V
Sustaining Voltage at $\overline{OUTn}$		$V_{DSn}$	$-0.5 \sim +50$	V
Sustaining Voltage at FB		$V_{FB}$	5	V
Sustaining Voltage at CHD		$V_{CHD}$	5	V
Output Current		$I_{OUTn}$	66*	mA
GND Terminal Current		$I_{GND}$	520	mA
Power Dissipation* (On PCB, $T_a=25^\circ\text{C}$ )	GTS	$P_D$	1.29	W
	GFN		2.95	
Thermal Resistance** (By simulation)	GTS	$R_{th(j-a)}$	97.15	$^\circ\text{C/W}$
	GFN		42.37	
Empirical Thermal Resistance*** (On PCB, $T_a=25^\circ\text{C}$ )	GTS		103.15	
	GFN		99.73	
Operating Junction Temperature		$T_{j,max}$	125	$^\circ\text{C}$
Operating Temperature		$T_{opr}$	$-40 \sim +85$	$^\circ\text{C}$
Storage Temperature		$T_{stg}$	$-55 \sim +150$	$^\circ\text{C}$

\*Users must notice that the power dissipation (almost equaling to  $I_{OUT} \times V_{DS}$ ) should be within the Safe Operation Area shown in Figure 16.

\*\*The performance of thermal dissipation is strongly related to the size of thermal pad, thickness and layer numbers of the PCB. The empirical thermal resistance may be different from simulative value. Users should plan for expected thermal dissipation performance by selecting package and arranging layout of the PCB to maximize the capability.

\*\*\*The PCB size is 4 times larger than the size of IC and without extra heat sink.

Electrical Characteristics

VDD=12V, GND =0V, Ta=25°C, unless otherwise specified.

Characteristic		Symbol	Condition	Min.	Typ.	Max.	Unit
Supply Voltage		V <sub>DD</sub>	-	8	-	40	V
Input Voltage of OE	“High” level	V <sub>OE,IH</sub>	T <sub>a</sub> = -40~85°C	2.8	-	V <sub>DD</sub>	V
	“Low” level	V <sub>OE,IL</sub>	T <sub>a</sub> = -40~85°C	GND	-	0.7	V
Output Voltage of $\overline{\text{ERR}}$		V <sub>ERR,OH</sub>	I <sub>ERR,OH</sub> = 1.0mA	4.2	-	5	V
		V <sub>ERR,OL</sub>	I <sub>ERR,OL</sub> = 1.0mA	-	-	0.5	V
Output Voltage of $\overline{\text{TH}}$		V <sub>TH,OH</sub>	I <sub>TH,OH</sub> = 1.0mA	4.2	-	5	V
		V <sub>TH,OL</sub>	I <sub>TH,OL</sub> = 1.0mA	-	-	0.5	V
V <sub>OUT</sub> Feedback Report Voltage		V <sub>FB</sub>	V <sub>OUT(min)</sub> =0.8V	-	1.25	-	V
Supply Current	OE=Low	I <sub>DD(off) 1</sub>	R <sub>ext</sub> = Open, $\overline{\text{OUT0}} \sim \overline{\text{OUT7}} = \text{Off}$	-	0.57	2.5	mA
		I <sub>DD(off) 2</sub>	R <sub>ext</sub> = 2.4kΩ, $\overline{\text{OUT0}} \sim \overline{\text{OUT7}} = \text{Off}$	-	0.57	3.5	
		I <sub>DD(off) 3</sub>	R <sub>ext</sub> = 1.3kΩ, $\overline{\text{OUT0}} \sim \overline{\text{OUT7}} = \text{Off}$	-	0.57	4	
	OE=High	I <sub>DD(on) 1</sub>	R <sub>ext</sub> = 2.4kΩ, $\overline{\text{OUT0}} \sim \overline{\text{OUT7}} = \text{On}$	2.5	3.17	5	
		I <sub>DD(on) 2</sub>	R <sub>ext</sub> = 1.3kΩ, $\overline{\text{OUT0}} \sim \overline{\text{OUT7}} = \text{On}$	3.0	3.55	5	
Standby Current		I <sub>DD(std)</sub>	OE= low, OE waits for 825us	-	0.57	1	mA
Output Current		I <sub>OUT</sub>	Test Circuit for Electrical Characteristics	5	-	60*	mA
Output Leakage Current		I <sub>OH</sub>	V <sub>DS</sub> = 40.0V, OE=Low	-	-	0.5	μA
Output Current 1		I <sub>OUT1</sub>	V <sub>DS</sub> = 0.6V, R <sub>ext</sub> = 2.4kΩ	-	30.75	-	mA
Current Skew 1		dI <sub>OUT1</sub>	I <sub>OUT1</sub> = 30.75mA, V <sub>DS</sub> = 0.6V, R <sub>ext</sub> = 2.4kΩ	-	±1	±3	%
Output Current 2		I <sub>OUT2</sub>	V <sub>DS</sub> = 0.8V, R <sub>ext</sub> = 1.3kΩ	-	56.7	-	mA
Current Skew 2		dI <sub>OUT2</sub>	I <sub>OUT2</sub> = 56.7mA, V <sub>DS</sub> = 0.8V, R <sub>ext</sub> = 1.3kΩ	-	±1	±3	%
Current Chip Skew			V <sub>DS</sub> = 0.6V, I <sub>OL</sub> = 24.6mA, R <sub>ext</sub> = 3kΩ		-	±6	%
Output Current vs. Output Voltage Regulation		%/dV <sub>DS</sub>	V <sub>DS</sub> within 1.0V and 3.0V	-	±0.1	±0.5	% / V
Output Current vs. Supply Voltage Regulation		%/dV <sub>DD</sub>	V <sub>DD</sub> within 8.0V and 40V	-	±0.1	±0.5	% / V
Pull-down Resistor of OE		R <sub>OE-IN</sub>	-	280	400	520	KΩ
Junction Temperature Threshold of Thermal flag		T <sub>x</sub>	-	-	155	-	°C
The Hysteresis Temperature of Thermal Flag		T <sub>hys</sub>	-	-	35	-	°C

\*Each output current, I<sub>OUT</sub>, can be driven up to 60mA.

Test Circuit for Electrical Characteristics

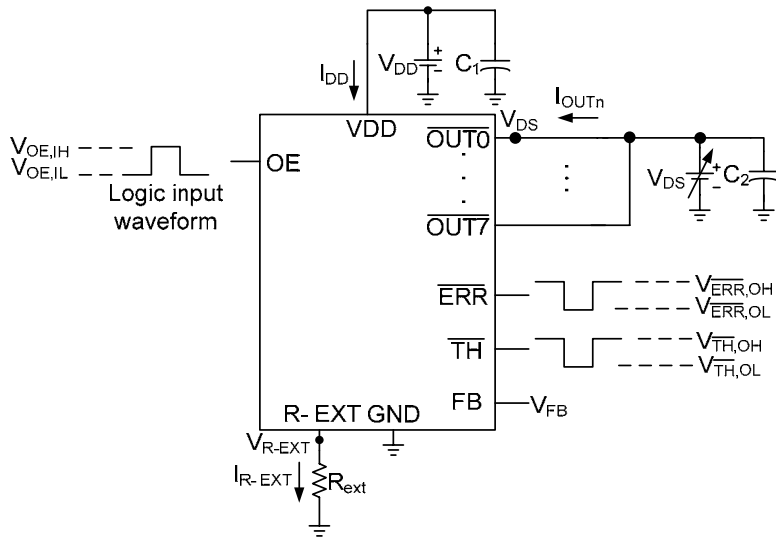

Figure 2  
Switching Characteristics

Characteristic		Symbol	Condition	Min.	Typ.	Max.	Unit
Propagation Delay Time ("L" to "H")	OE - $\overline{\text{OUTn}}$	$t_{\text{pLH}}$	$V_{\text{DD}} = 12.0 \text{ V}$ $V_{\text{DS}} = 1.0 \text{ V}$	-	1.88	2.5	$\mu\text{s}$
Propagation Delay Time ("H" to "L")	OE - $\overline{\text{OUTn}}$	$t_{\text{pHL}}$	$V_{\text{IH}} = 5 \text{ V}$ $V_{\text{IL}} = \text{GND}$	-	1.3	2.5	$\mu\text{s}$
OE Pulse Width		$t_{\text{w(OE)}}$	$R_{\text{ext}} = 1227 \Omega$ ( $I_{\text{OUTn}} = 60 \text{ mA}$ )	5	-	-	$\mu\text{s}$
Output Rise Time of $\overline{\text{OUTn}}$ (turn off)		$t_{\text{or}}$	$V_{\text{LED}} = 4.2 \text{ V}$ $R_{\text{L}} = 51 \Omega$	-	1.5	2.5	$\mu\text{s}$
Output Fall Time of $\overline{\text{OUTn}}$ (turn on)		$t_{\text{of}}$	$C_{\text{L}} = 10 \text{ pF}$ Refer to Figure 4	-	1.8	2.5	$\mu\text{s}$
Standby Time		$t_{\text{std}}$	Refer to Figure 5	491	-	825	$\mu\text{s}$
$\overline{\text{ERR}}$ Delay Time		$t_{\text{err}}$	Refer to Figure 6	-	-	1000	ms
FB Delay Time	$V_{\text{DS}} - \text{FB}$	$t_{\text{FB}}$	Refer to Figure 7	-	-	200	ns

Note: Where the "n" of  $\overline{\text{OUTn}}$  refers to 0~7.

Test Circuit for Switching Characteristics

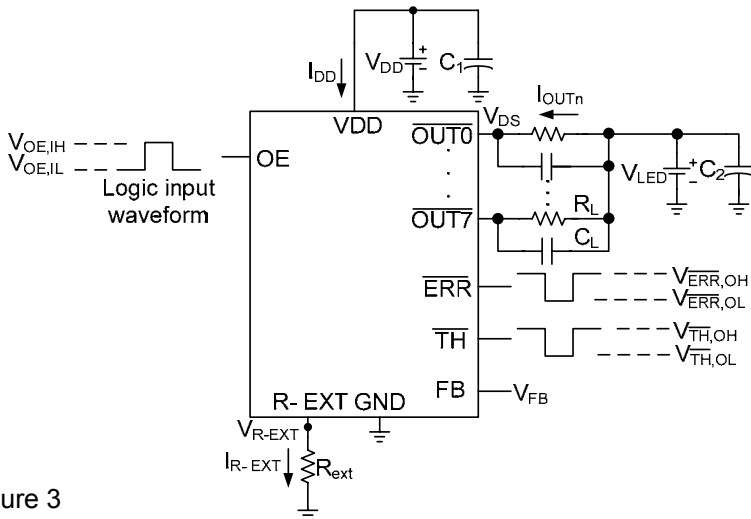

Figure 3

Timing Waveform

A. Propagation Delay Time Timing Waveform

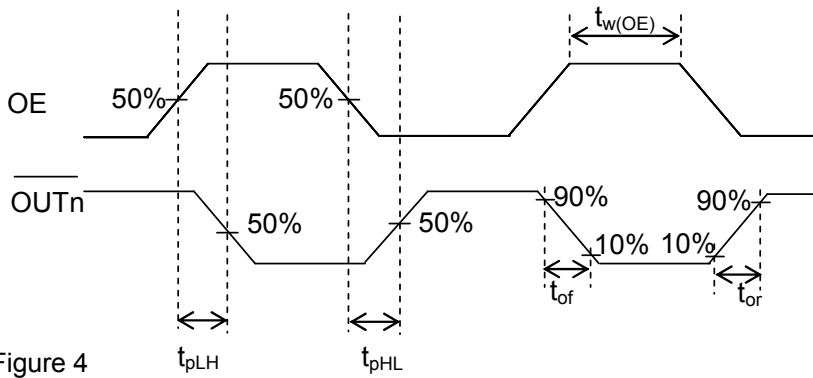
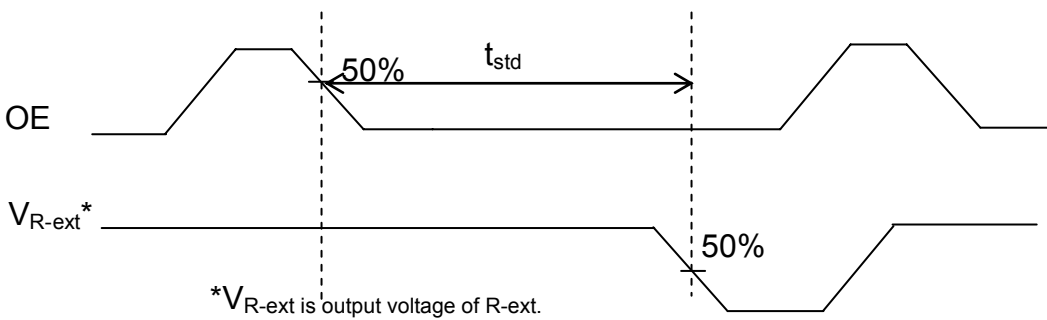

Figure 4

B. Standby Time Timing Waveform



\* $V_{R-ext}$  is output voltage of R-ext.

Figure 5

C.  $\overline{ERR}$  Delay Time Timing Waveform

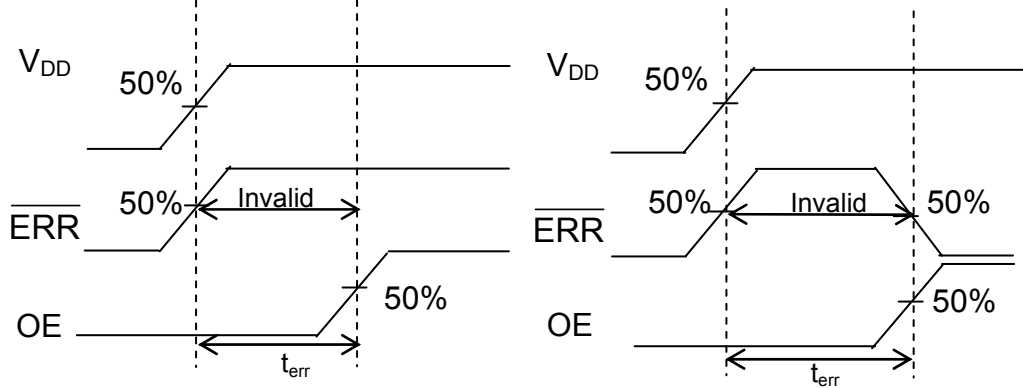

Figure 6

D. FB Delay Time Timing Waveform

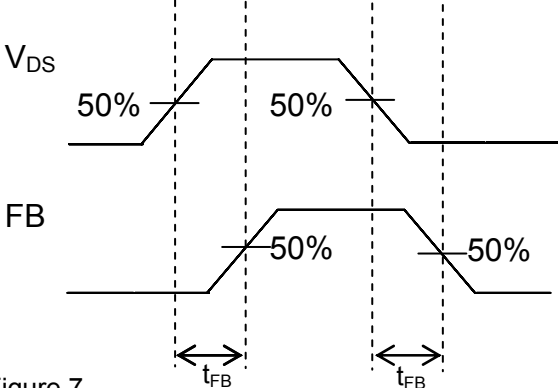

Figure 7

Typical Application Circuits

1.  $V_{LED}$  and  $V_{DD}$  share a single voltage source

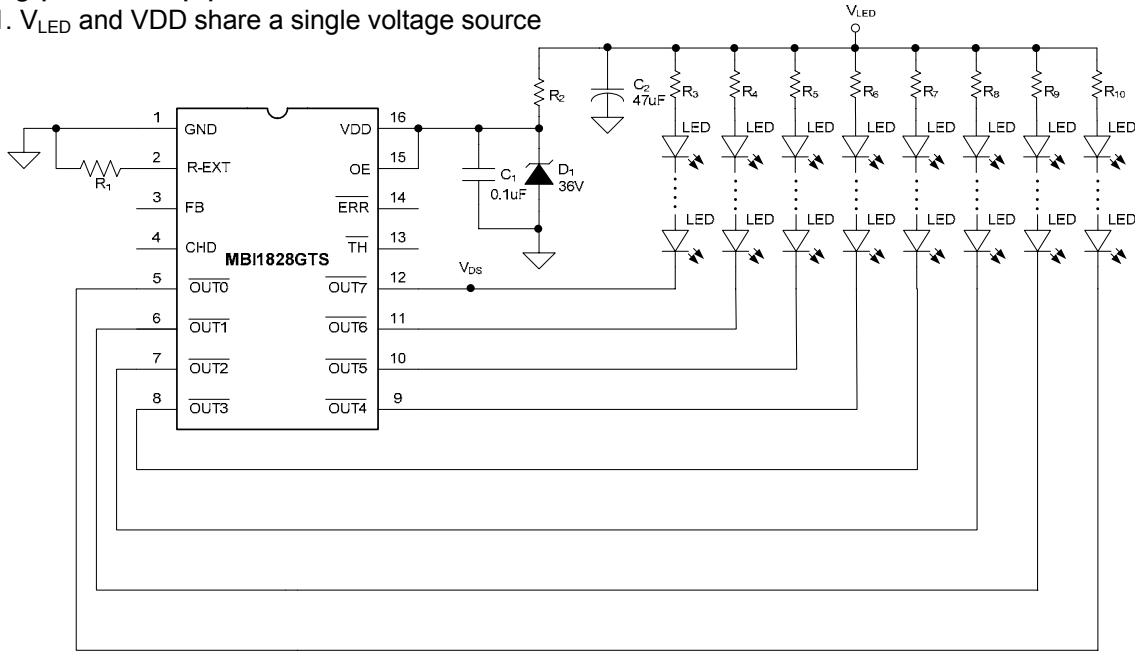

Figure 8

Assume  $V_{F,LED} \times n$  are the same.

$V_{LED}$  and  $V_{DD}$  share a single voltage source.

$V_{LED} > V_{DS} + V_{F,LED} \times n$ ;  $V_{F,LED}$ : Forward voltage of LED.

$R_2 = (V_{LED} - 36V) / I_{DD}$ ; refer to Electrical Characteristics for  $I_{DD}$ .

$R_3 = R_4 = \dots = R_{10} = [V_{LED} - V_{DS} - (V_{F,LED} \times n)] / I_{OUT}$ ; n refer to LED count.

2.  $V_{LED}$  and  $V_{DD}$  are separated voltage source

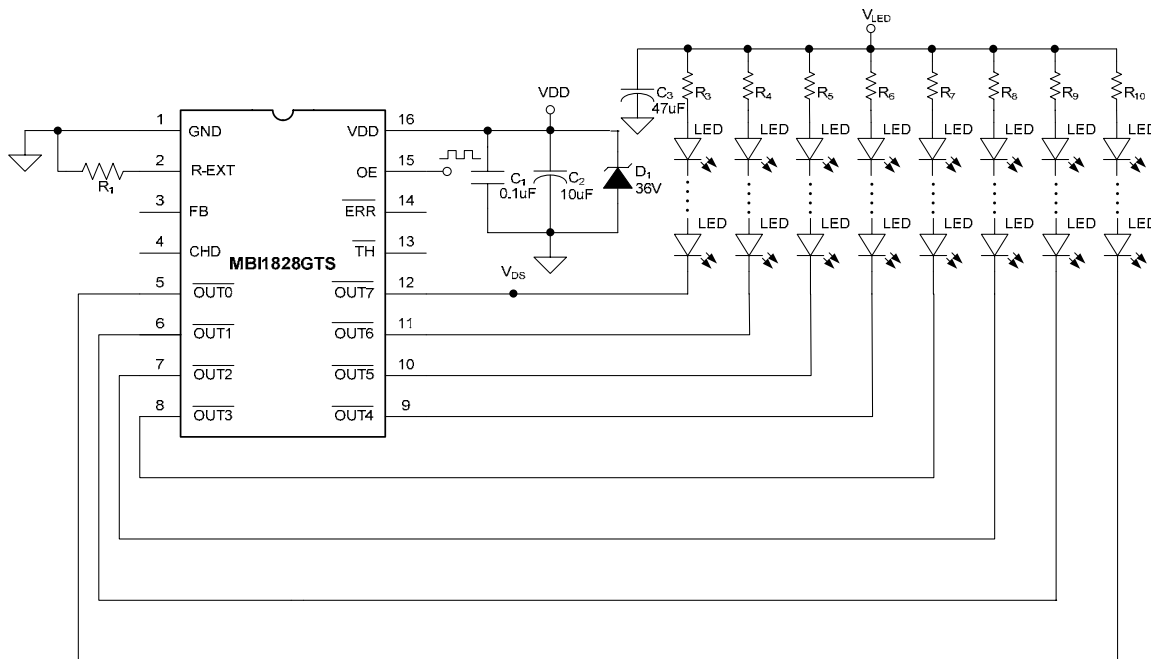

Figure 9

$V_{LED}$  and  $V_{DD}$  are separated. The capacitor  $C_2$  is required to get close to MBI1828.

$V_{LED} > V_{DS} + V_{F,LED} \times n$ ;  $V_{F,LED}$ : Forward voltage of LED.

$R_2 = (V_{LED} - 36V) / I_{DD}$ ; refer to Electrical Characteristics for  $I_{DD}$ .

$R_3 = R_4 = \dots = R_{10} = [V_{LED} - V_{DS} - (V_{F,LED} \times n)] / I_{OUT}$ ; n refer to LED count.



### Constant Current

In LED lighting applications, MBI1828 provides nearly no variation in current from channel to channel and from IC to IC. This can be achieved by:

- 1) The maximum current variation between channels is less than  $\pm 3\%$ , and that between ICs is less than  $\pm 6\%$ .
- 2) In addition, the current characteristic of output stage is flat and users can refer to Figure 10. The output current can be kept constant regardless of the variations of LED forward voltages ( $V_F$ ). This guarantees LED to be performed on the same brightness as user's specification.

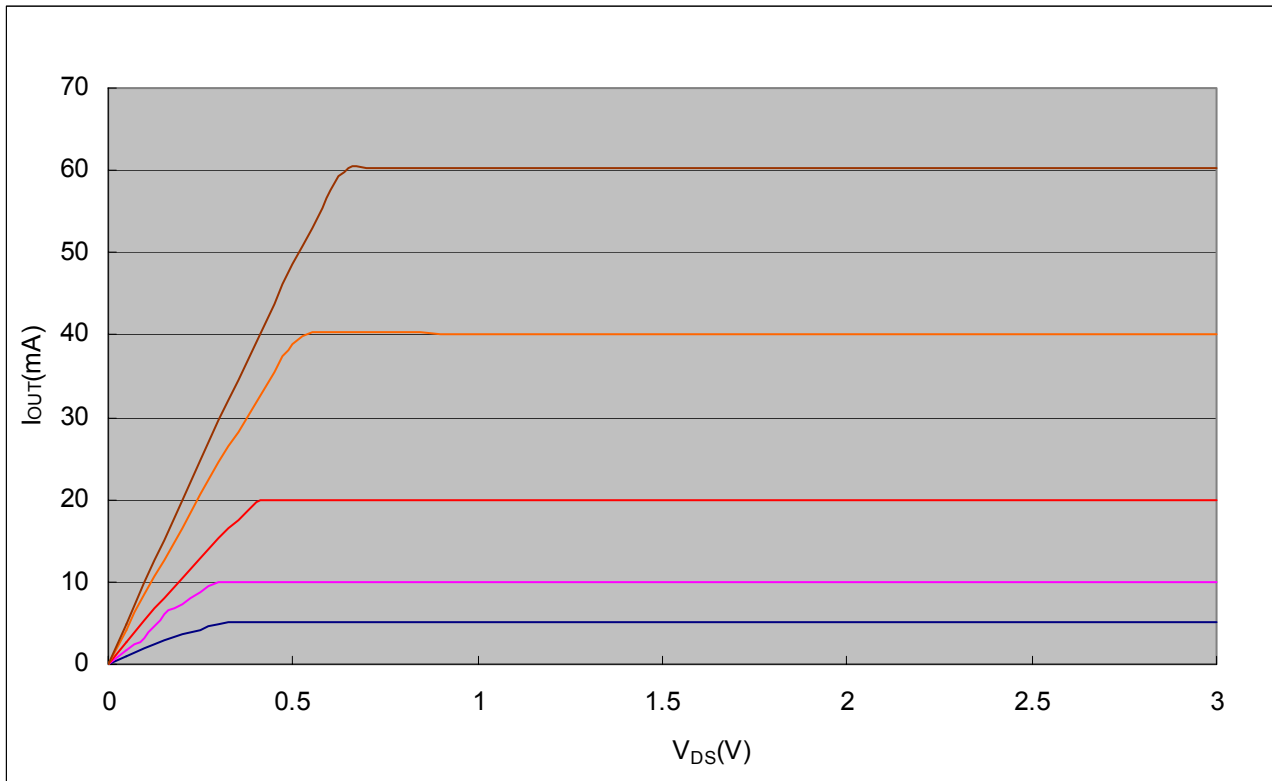

Figure 10

## Setting Output Current

The output current of each channel ( $I_{OUT}$ ) is set by an external resistor,  $R_{EXT}$ . The relationship between  $I_{OUT}$  and  $R_{EXT}$  is shown in Figure 11.

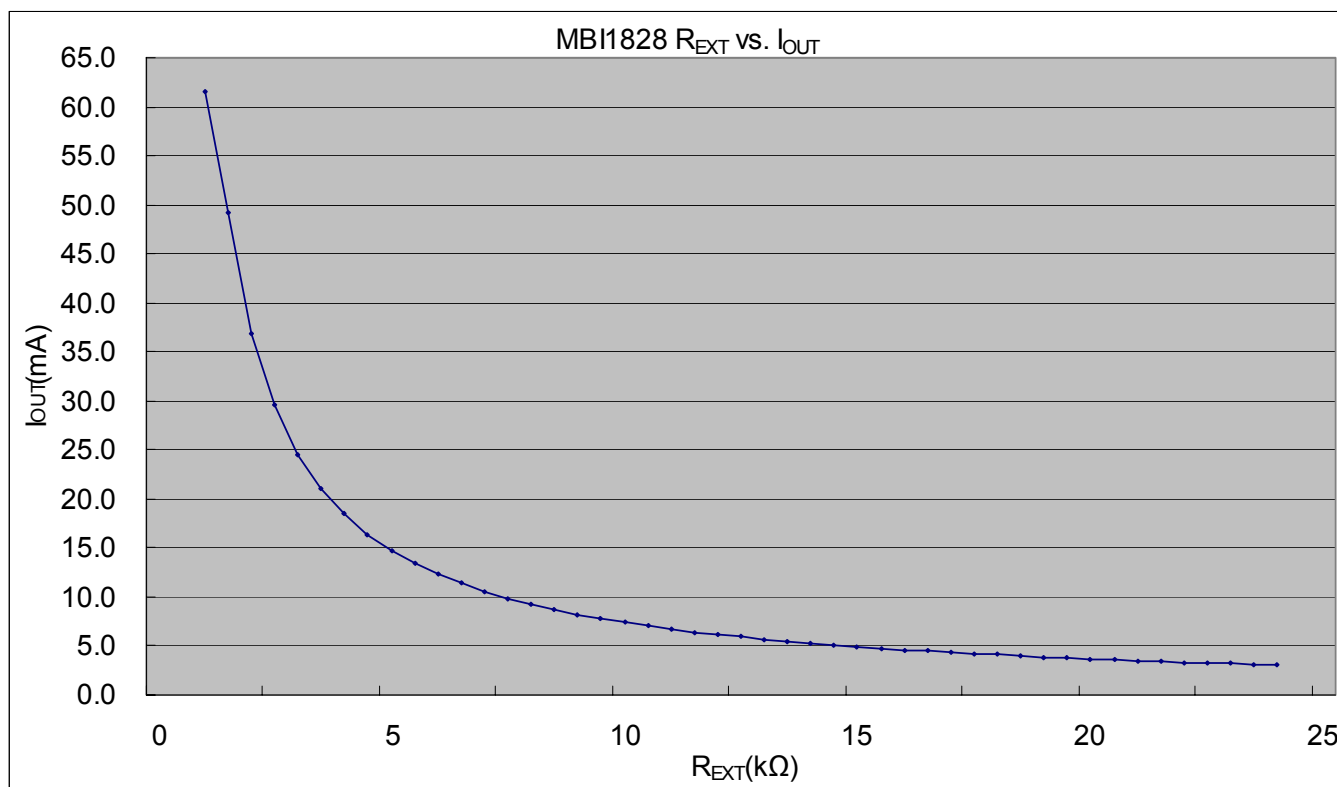

Figure 11

Also, the output current can be calculated from the equation:

$$V_{R-EXT} = 1.23V;$$

$$R_{ext} = (V_{R-EXT} / I_{OUT}) \times 60 = (1.23V / I_{OUT}) \times 60;$$

$$I_{OUT} = (V_{R-EXT} / R_{ext}) \times 60 = (1.23V / R_{ext}) \times 60 \text{ within } \pm 6\% \text{ chip skew};$$

where  $R_{ext}$  is the resistance of the external resistor connecting to R-EXT terminal and  $V_{R-EXT}$  is the voltage of R-EXT terminal. The magnitude of current (as a function of  $R_{ext}$ ) is around 56.7mA at 1.3kΩ and 30.75mA at 2.4kΩ.

## Open-Circuit Detection

The principle of LED open-circuit detection is based on the fact that when output voltage ( $V_{DS}$ ) is lower than 0.3V. The  $\overline{ERR}$  pin will become low. Before activating open-circuit detection, MBI1828 will check CHD pin first. Once it confirms, the open-circuit detection will bypass those non-used pins which are connected to CHD.

## Thermal Detection

When the junction temperature exceeds the threshold,  $T_x$  (155°C), the thermal flag would be enabled. The  $\overline{TH}$  pin will become low. As soon as the temperature is below 120°C, the  $\overline{TH}$  will go high again.

## Standby Operation

When OE goes low for 825us ( $t_{std}$ , max.), there will be standby operation. When IC enter in standby, there will be no voltage to generate  $V_{R-ext}$  and the supply current ( $I_{DD}$ ) will lower to 1mA (max.).

# MBI1828 8-Channel All-Ways-On™ Constant-Current LED Driver

## Principle to Cooperate with DC/DC Converter (Boost converter)

MBI1828 can co-work with DC/DC converter through FB terminal. The voltage of FB terminal is  $V_{FB} = 1.56 \times (V_{DS, min})$  to make  $V_{DS}$  reaching 0.8V. When the minimum  $V_{DS}$  of MBI1828 in any single channel is lower than 0.8V, the  $V_{FB}$  will force DC/DC controller to boost  $V_{LED}$  as shown in Figure 12.

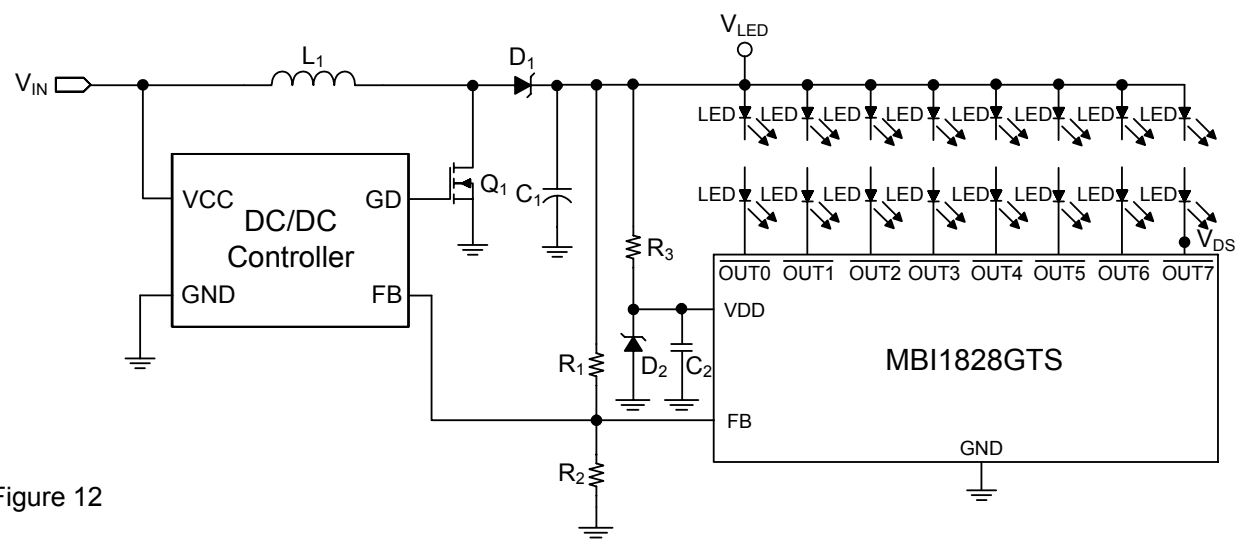

Figure 12

### The Scheme of FB Terminal

When OE is disabled, the FB becomes high impedance (also known as floating). When OE is enabled, the minimum voltage selector will ignore to connect CHD and open-circuit output channels. The rest of output channels will select the minimum voltage ( $V_{min}$ ) through the selector and increase to 1.56 times of  $V_{min}$  as the voltage of FB. The maximum voltage of FB terminal is 2.3V as shown in Figure 14. The output status of FB ( $V_{FB, MBI1828}$ ) will be determined by  $I_{OUTn, max}$ , the FB voltage of DC/DC converter ( $V_{FB, DC/DC}$ ), and  $\overline{ERR}$  status shown in Table 1:

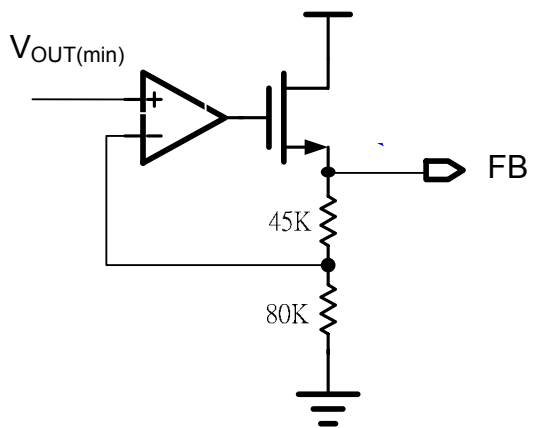

Figure 13. The relationship between  $V_{FB}$  and  $V_{DS}$  of MBI1828

OE	$I_{OUTn, max} > 0.9I_{REF}$	ERR is High	$V_{FB, DC/DC} > 1.19V$	$V_{FB, MBI1828}$
Disable	Don't care	Don't care	Don't care	High Impedance
Enable	FALSE	Don't care	Don't care	High Impedance
Enable	TRUE	FALSE	FALSE	High Impedance
Enable	TRUE	FALSE	TRUE	$1.56 \times V_{min}$
Enable	TRUE	TRUE	TRUE	$1.56 \times V_{min}$

Table1. True Table of  $V_{FB, MBI1828}$

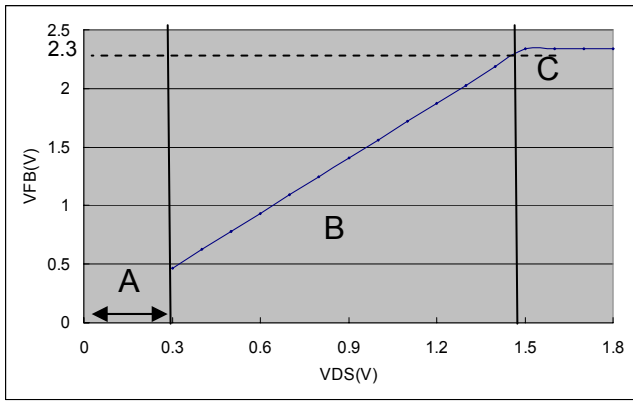

Figure 14. The relationship between  $V_{FB}$  and  $V_{DS}$  of MBI1828. The area A is High Impedance. The area B is  $V_{FB(V)}=1.56 \times V_{DS(min)}$ . The area C is Saturation.

As noted previously, MBI1828 reports open-circuit event and results in  $\overline{ERR}$  signal change. To avoid false alarm of error report, there should be a 1000ms delay time ( $t_{err}$ ) after  $V_{DD}$  builds up. In Figure 15 (a), the  $\overline{ERR}$  is invalid during this delay period and remains high level after the delay time. However, if IC detects the real open-circuit event after the delay time, the  $\overline{ERR}$  goes low and the error report shows open-circuit event as shown in Figure 15 (b). However, there are 2 points of power on sequence should be aware when applying DC/DC controller:

1. OE pin cannot directly connect to  $\overline{ERR}$ ,  $\overline{TH}$ , and VDD pins. OE should be addressed after 1000ms delay time of  $V_{DD}$ .
2. The output voltage of DC/DC converter is decided by a voltage divider,  $V_{LED}=V_{FB}(1+(R1/R2))$ . This output voltage of DC/DC converter should be 1V higher than maximum LED forward voltage.

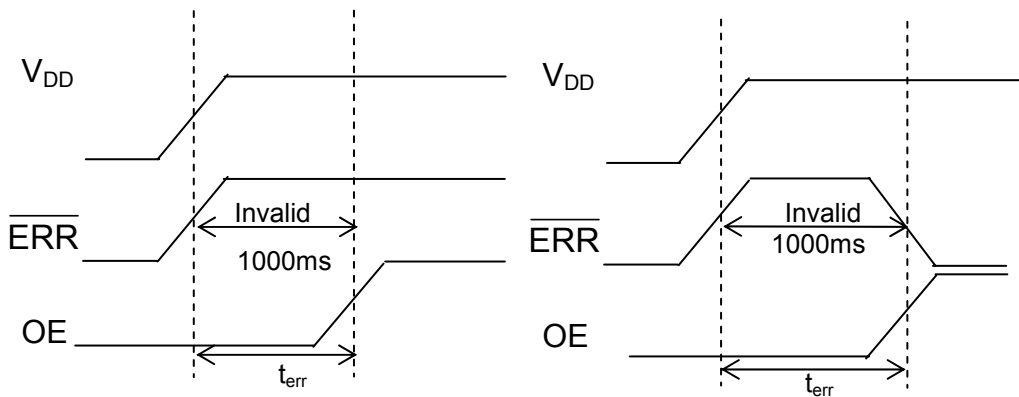

Figure 15 The waveform of power on sequence

(a) If there is no open-circuit event, the  $\overline{ERR}$  remains high after the delay time.

(b) If IC detects the real open-circuit event after the delay time, the  $\overline{ERR}$  goes low and report open-circuit event.

Package Power Dissipation ( $P_D$ )

The maximum power dissipation,  $P_D(max) = (T_{j,max} - T_a) / R_{th(j-a)}$ , decreases as the ambient temperature increases.

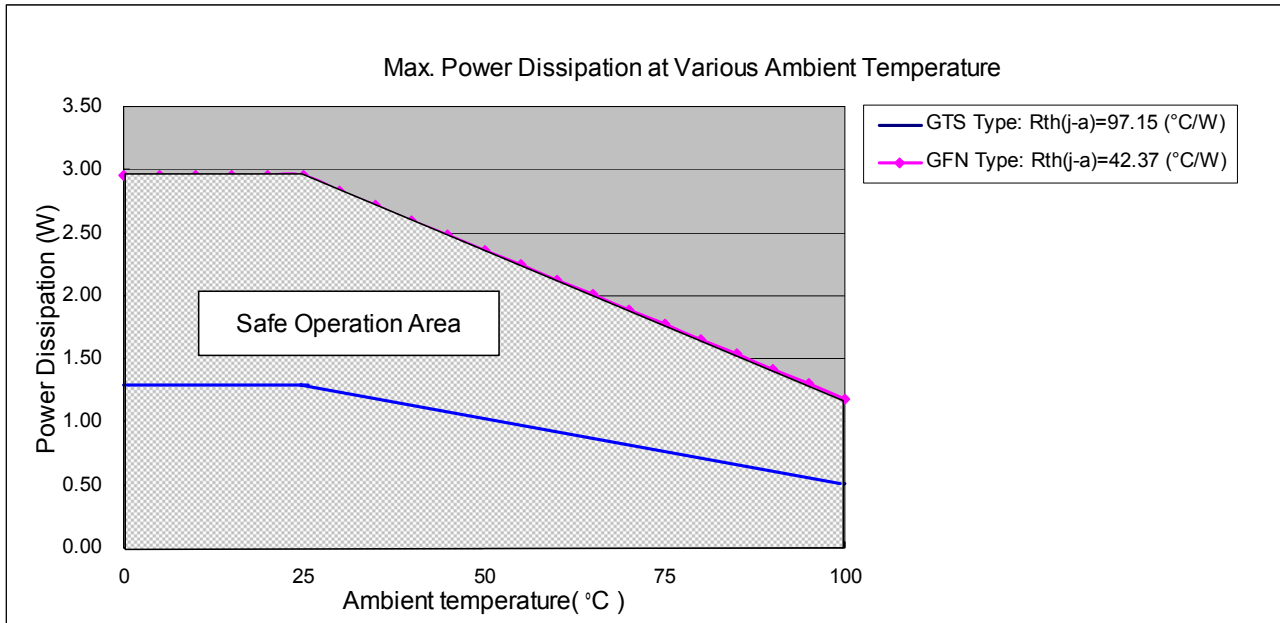

Figure 16

The maximum allowable package power dissipation is determined as  $P_D(max) = (T_{j,max} - T_a) / R_{th(j-a)}$ . When 8 output channels are turned on simultaneously, the actual package power dissipation is  $P_D(act) = (I_{DD} \times V_{DD}) + (I_{OUT} \times \text{Duty} \times V_{DS} \times 8)$ . Therefore, to keep  $P_D(act) \leq P_D(max)$ , the allowable maximum output current as a function of duty cycle is:

$$I_{OUT} = \{ [(T_{j,max} - T_a) / R_{th(j-a)}] - (I_{DD} \times V_{DD}) \} / V_{DS} / \text{Duty} / 8,$$

where  $T_{j,max} = 125^\circ\text{C}$ ;

Duty =  $t_{ON} / T$ ;

$t_{ON}$ : the time of LEDs turning on; T: OE signal period

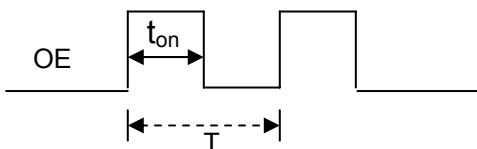

\*Note: The empirical thermal resistor  $R_{th(j-a)} = 103.15 \text{ } ^\circ\text{C/W}$ ; it is based on the following structure.

Usage of Thermal Pad

The PCB area  $L2 \times W2$  is 4 times (min.) of the IC's area  $L1 \times W1$ . The thickness of the PCB is 1.6mm, copper foil 1 Oz. The thermal pad on the IC's bottom has to be mounted on the copper foil.

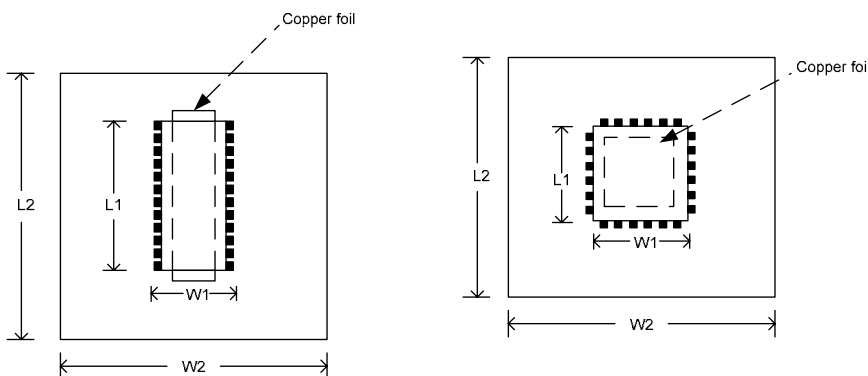

## Load Supply Voltage ( $V_{LED}$ )

MBI1828 is designed to operate with adequate  $V_{DS}$  to achieve constant current.  $V_{DS}$  and  $I_{OUT}$  should not exceed the package power dissipation limit,  $P_D(max)$ .

$V_{DS} = V_{LED} - V_F$ , and  $V_{LED}$  is the load supply voltage. If  $V_{DS}$  drops too much voltage on the driver,  $P_D(act)$  will be greater than  $P_D(max)$ . In this case, it is recommended to use supply voltage as low as possible or to set an external voltage reducer,  $V_{DROP}$ .

A voltage reducer allows  $V_{DS} = (V_{LED} - V_F) - V_{DROP}$ .

Resistors can be used in the applications as shown in Figure17.

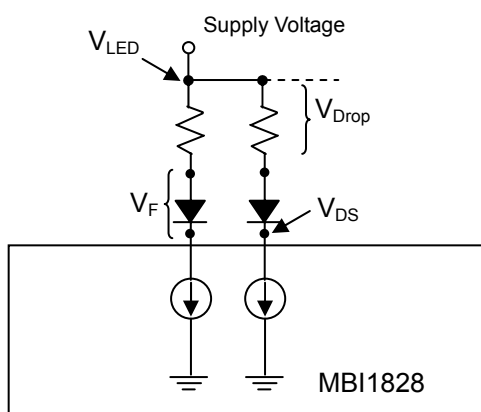
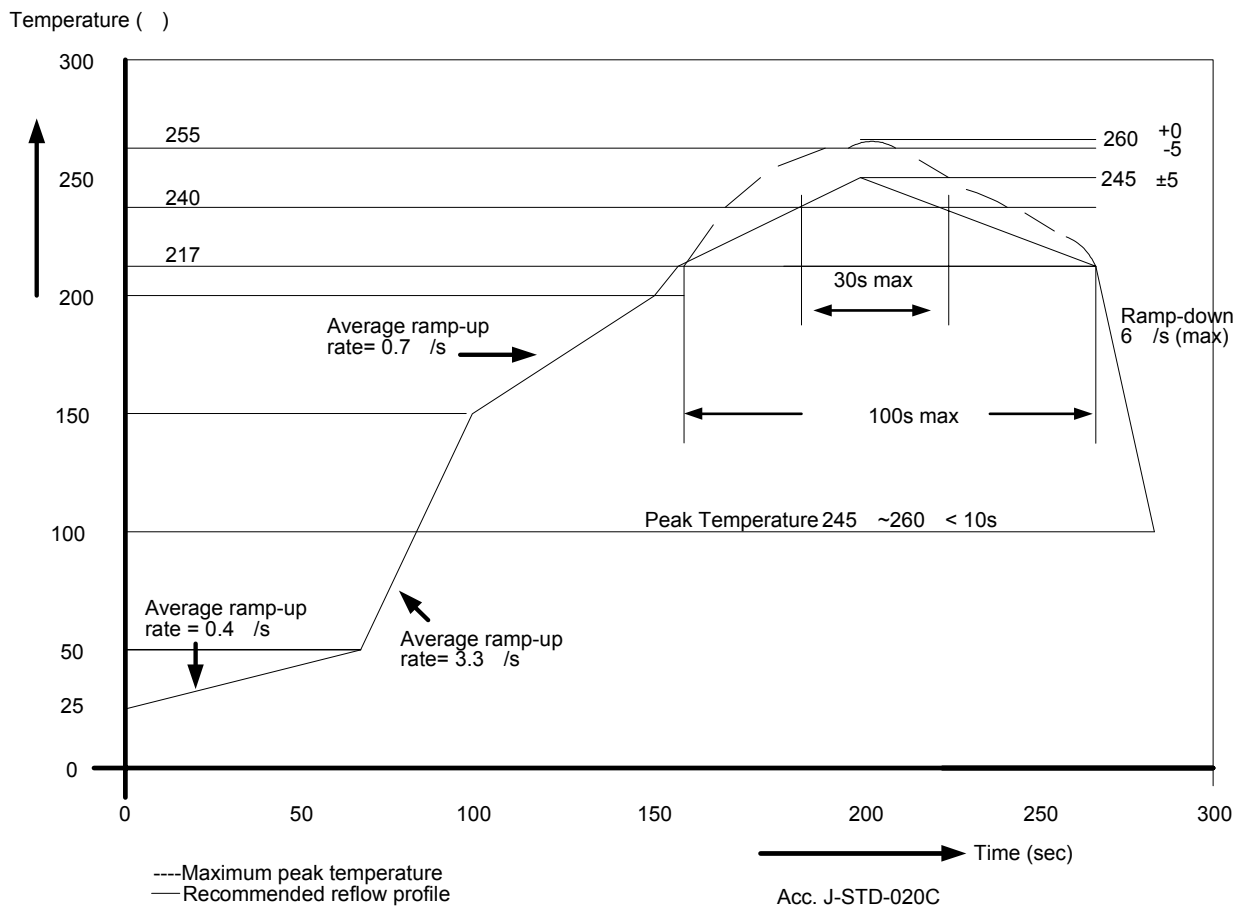

Figure 17

Soldering Process of "Pb-free & Green" Package Plating\*

Macroblock has defined "Pb-Free & Green" to mean semiconductor products that are compatible with the current RoHS requirements and selected 100% pure tin (Sn) to provide forward and backward compatibility with both the current industry-standard SnPb-based soldering processes and higher-temperature Pb-free processes. Pure tin is widely accepted by customers and suppliers of electronic devices in Europe, Asia and the US as the lead-free surface finish of choice to replace tin-lead. Also, it is backward compatible to standard 215°C to 240°C reflow processes which adopt tin/lead (SnPb) solder paste. However, in the whole Pb-free soldering processes and materials, 100% pure tin (Sn) will all require up to 260 °C for proper soldering on boards. Please refer to J-STD-020C as shown below.



\*Note: For details, please refer to Macroblock's "Policy on Pb-free & Green Package".

Outline Drawing

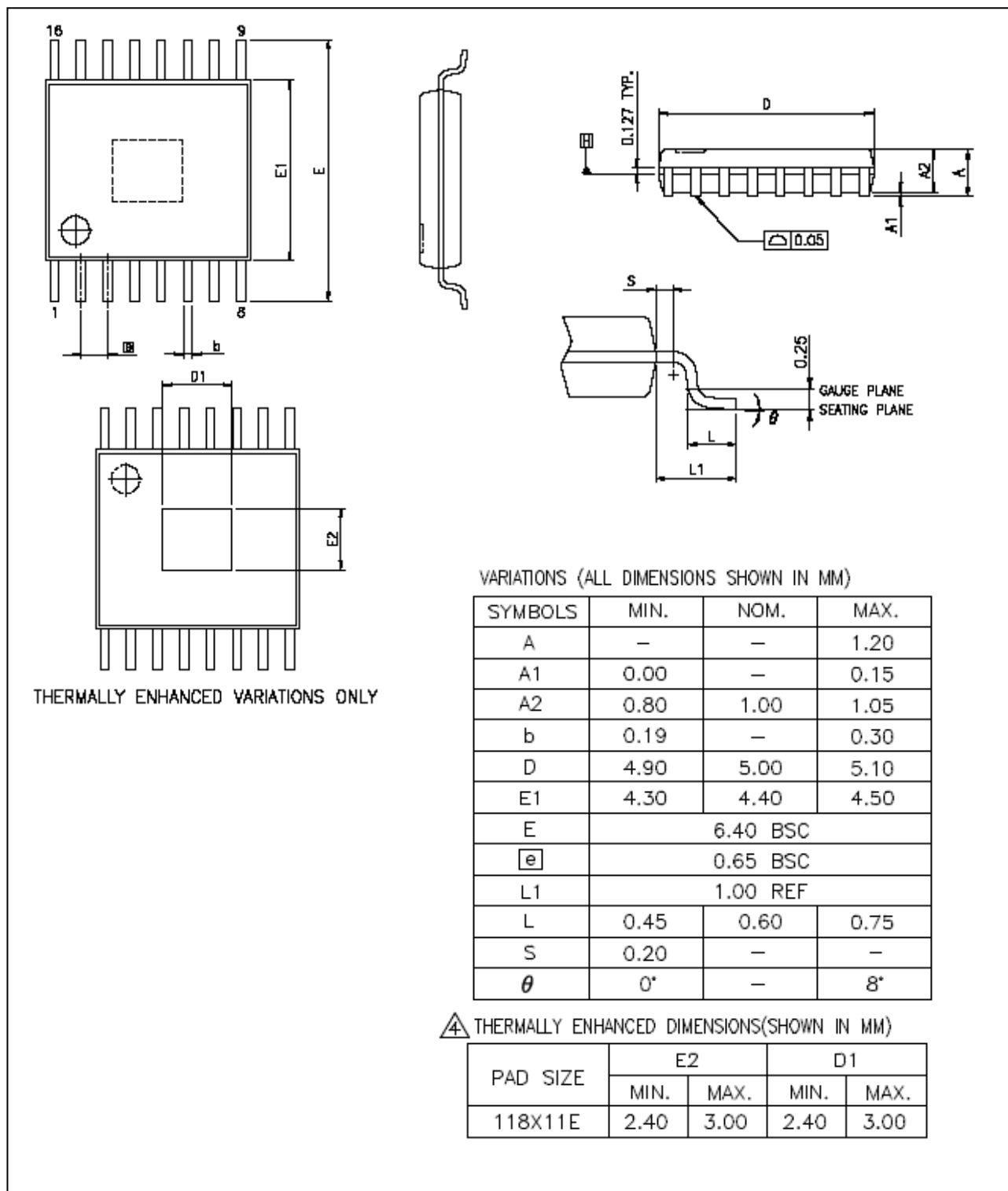

MBI1828 GTS Outline Drawing

Note: The unit for the outline drawing is mm. Please use the maximum dimensions for the thermal pad layout. To avoid the short circuit risk, the via or circuit traces shall not pass through the maximum area of thermal pad.



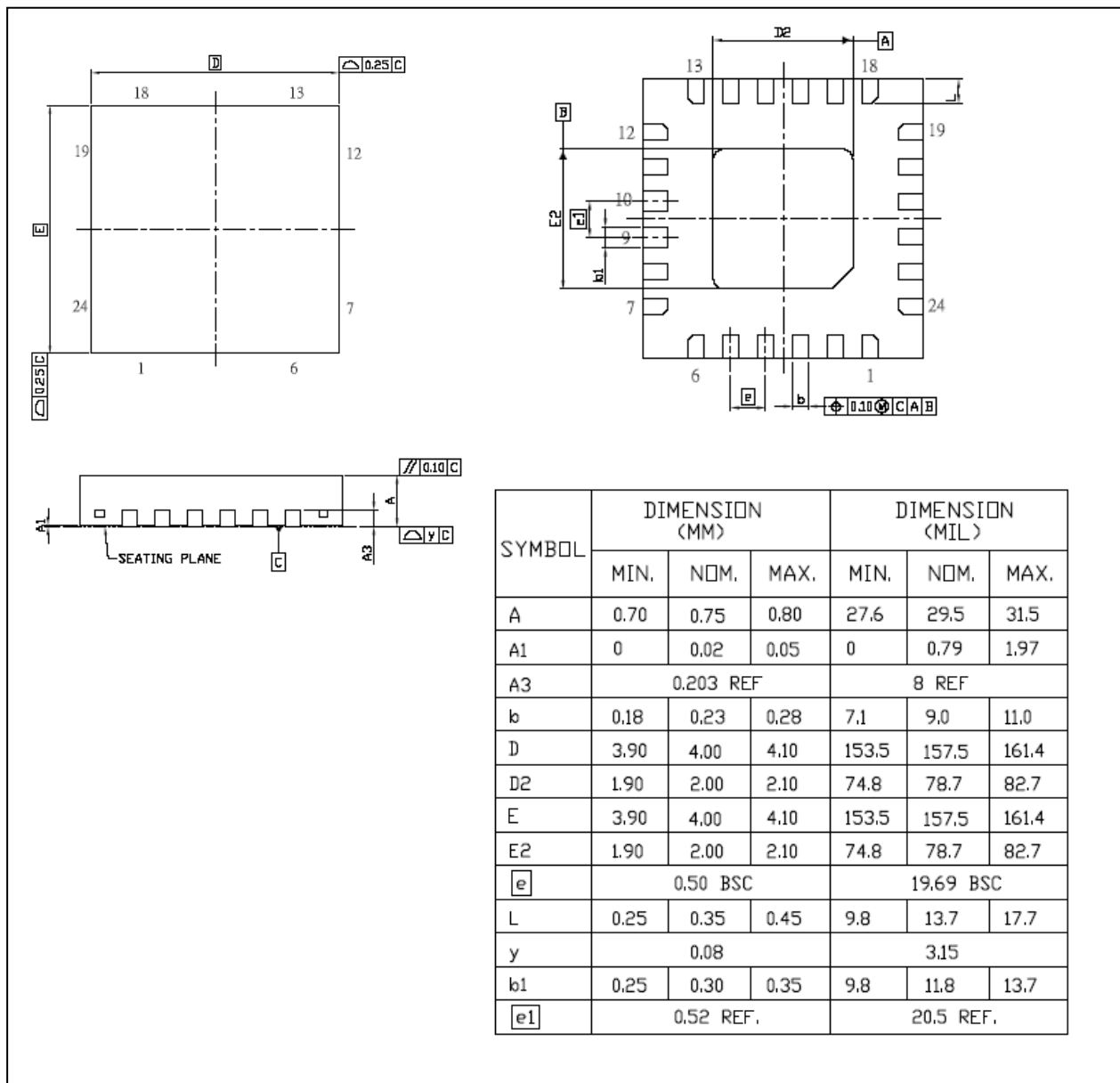

MBI1828 GFN Outline Drawing

Note: Please use the maximum dimensions for the thermal pad layout. To avoid the short circuit risk, the via or circuit traces shall not pass through the maximum area of thermal pad.

### Product Top-Mark Information

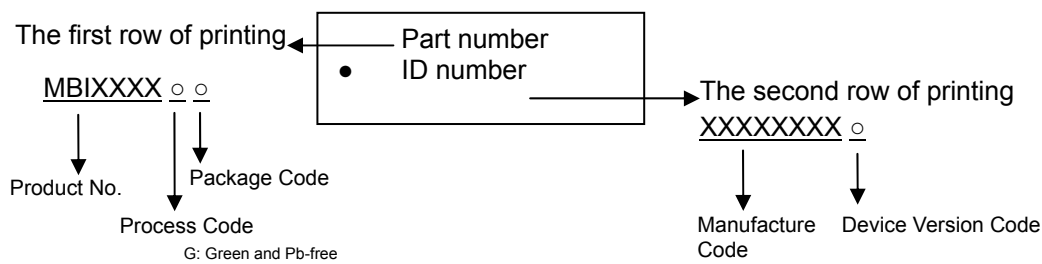

### Product Revision History

Datasheet Version	Device Version Code
V1.00	A
V1.01	A

### Product Ordering Information

Part Number	Package Type	Weight (g)
MBI1828GTS	TSSOP16-173-0.65	0.067
MBI1828GFN	QFN24-4*4- 0.5	0.0379

## Disclaimer

Macroblock reserves the right to make changes, corrections, modifications, and improvements to their products and documents or discontinue any product or service without notice. Customers are advised to consult their sales representative for the latest product information before ordering. All products are sold subject to the terms and conditions supplied at the time of order acknowledgement, including those pertaining to warranty, patent infringement, and limitation of liability.

Macroblock's products are not designed to be used as components in device intended to support or sustain life or in military applications. Use of Macroblock's products in components intended for surgical implant into the body, or other applications in which failure of Macroblock's products could create a situation where personal death or injury may occur, is not authorized without the express written approval of the Managing Director of Macroblock.

Macroblock will not be held liable for any damages or claims resulting from the use of its products in medical and military applications.

Related technologies applied to the product are protected by patents. All text, images, logos and information contained on this document is the intellectual property of Macroblock. Unauthorized reproduction, duplication, extraction, use or disclosure of the above mentioned intellectual property will be deemed as infringement.