

Descriptions

The DW8505 is an instant On/Off LED driver for high power LED applications. At DW8505 output stage, one regulated current port is designed to provide a uniform and constant current sink for driving LEDs within a large range of V_F variations. DW8505 easily provides users a consistent current source. User may adjust the output current from up to 100mA through an external resistor R_S , which gives users flexibility in controlling the light intensity of LEDs. In addition, users can precisely adjust LED brightness from 0% to 100% via output enable (EN) with Pulse Width Modulation. DW8505 also guarantees that LEDs can be cascaded to maximum

Features

- Constant output current invariant to supply and load voltage change
- 5V to 40V supply voltage
- Up to 100mA adjustable regulated output current
- Built-in thermal derating circuit
- Available PWM dimming control
- Output current adjusted through an external resistor
- TSV Package

Applications

- LED light bulbs
- Signage and decorative LED lighting
- General lighting of flat panel displays
- RGB backlighting LED driver
- Current stabilizer with DC/DC or AC/DC
- Automotive lighting
- General purpose constant current source

Typical Application Circuit

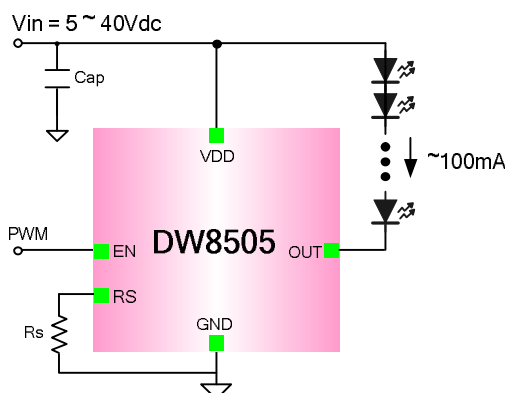

Ordering Information

Device	Marking	Package	Operating Temp
DW8505	E05	TSV	-35°C ~ +85°C

Package Information



Package	Size
TSV-5L	2.9 x 2.8 x 1(mm)

Pin Connection

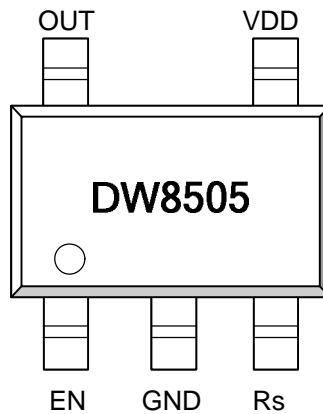

Pin Description

Pin	Name	Description
1	EN	Output stage enable control pin. High enable the OUT pin. Dimming control is possible by PWM (Pulse width modulation). Typically, It operates under 30kHz.
2	GND	Ground
3	RS	Output current set input. Connect a resistor from RS to GND to set the LED bias current
4	VDD	Supply voltage input
5	OUT	Output pin. Sink current is decided by the current on R_{SET} connected to RS

Absolute Maximum Ratings

Characteristics	Symbol	Value	Unit
Supply voltage	V_{DD}	41	V
Output voltage	V_{OUT}	23	V
Enable voltage	V_{EN}	41	V
Reference voltage	V_{RS}	5	V
Package thermal resistance	θ_{JA}	220	$^{\circ}C/W$
Operating temperature	T_{OPR}	-35~+85	$^{\circ}C$
Storage Temperature	T_{STG}	-55~+150	$^{\circ}C$

Note 1. θ_{ja} is measured in the convection at $T_a=25^{\circ}C$ on a high effective thermal conductivity test board(4 Layers, 2S2P) of JEDEC 51-7 thermal measurement standard.

Recommended Operation Conditions

Characteristics	Symbol	Min.	Typ.	Max.	Unit
Supply voltage	V_{DD}	5	-	40	V
Enable voltage	V_{EN}	-	-	40	V
Output sink current	I_{OUT}	-	-	100	mA

Electrical Characteristics

$V_{DD} = 24V$, $EN = 0 \sim 24V$, $T_a = -35^{\circ}C \sim +85^{\circ}C$, unless otherwise specified. Typical values are at $T_A = +25^{\circ}C$

Characteristics	Symbol	Conditions	Min.	Typ.	Max.	Unit
Input supply voltage	V_{DD}		5	-	40	V
Output linearity voltage	V_{OUT_LINE}	$V_{DD}=24V$, $I_{SET}=60mA$,	-	-	3	V
Output current	I_{OUT}		-	-	100	mA
Quiescent Current	I_{Q_ON}	$EN = 24V$	0.3	0.45	1	mA
	I_{Q_OFF}	$EN = 0V$	85	120	250	μA
EN input leakage current	I_{EN_LIK}		30	45	60	μA
Input high voltage	V_{IH}		2	-	-	V
Input low voltage	V_{IL}		-	-	0.8	V
LED output drop-out voltage	V_{DROP}	$V_{DD}=24V$, $I_{SET}=60mA$	-	100	-	mV
Thermal derating	T_D		-	140	-	$^{\circ}C$
Thermal derating hysteresis	T_{DHYS}		-	15	-	$^{\circ}C$
Rset Voltage	V_{SET}		0.59	0.61	0.63	V
Output current by Rset	R_{SET}	30.5K Ω	19	20	21	mA
		10.1K Ω	57	60	63	mA
		6.1K Ω	95	100	105	mA

Note2 : Output dropout voltage : $90\% \times I_{OUT}$

Block Diagram

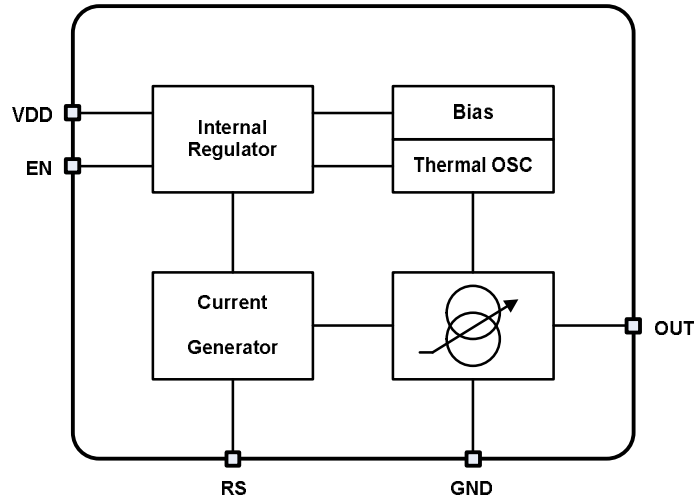

Application notice

Setting Output Current

$$I_{out} [mA] = (610[mV]/R_{set}[ohm]) \times 1000$$

Rset(kΩ)	Iout(mA)
30.5	20
10.16	60
6.1	100

Power sequence

There is an electrostatic diode between VDD and EN.
When dimming control, It must input EN signal after inputs VDD. ($t \geq 1ms$)
If not use Dimming control, EN connect to VDD.

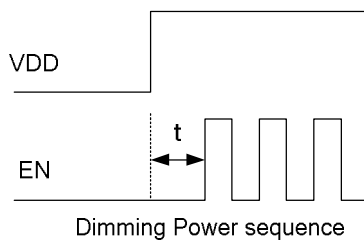

Electrical Characteristics Curves

$V_{DD} = 12V$, $V_{OUT} = 2V$, $T_a = -35^{\circ}C \sim +85^{\circ}C$, unless otherwise specified. Typical values are at $T_A = +25^{\circ}C$

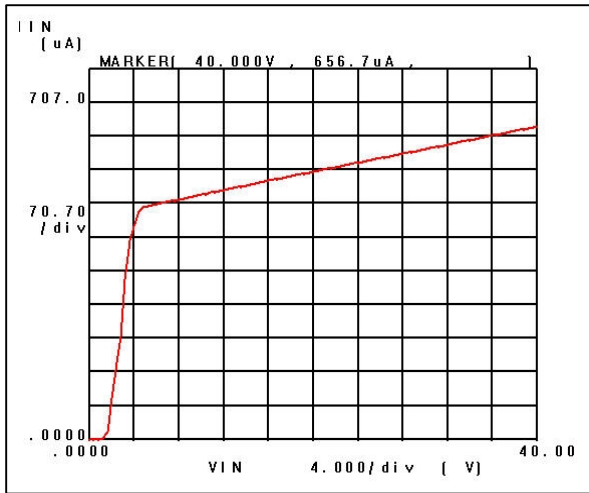

Quiescent vs. VDD

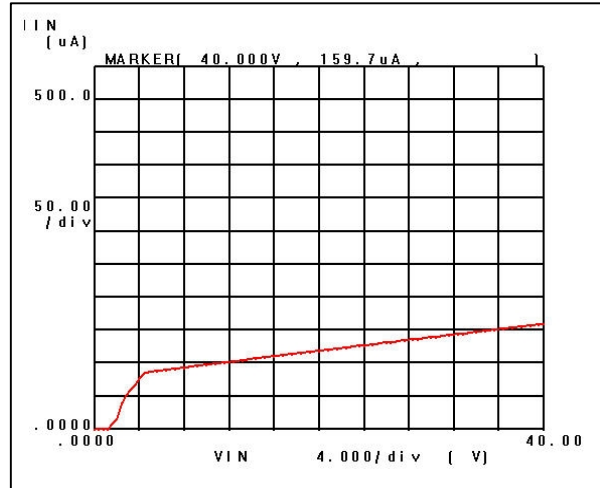

Ishutdown vs. VDD

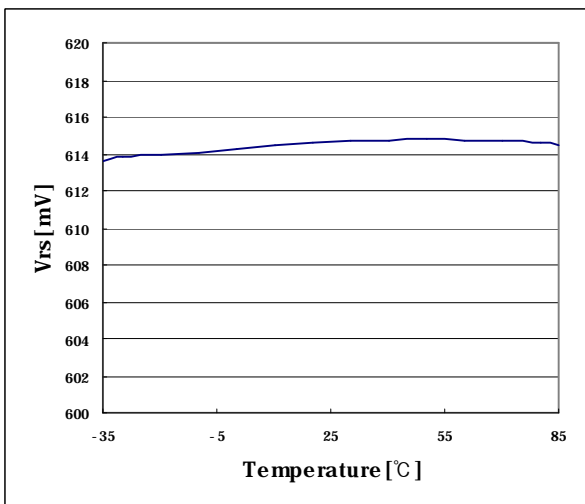

Vreference vs. Temp.

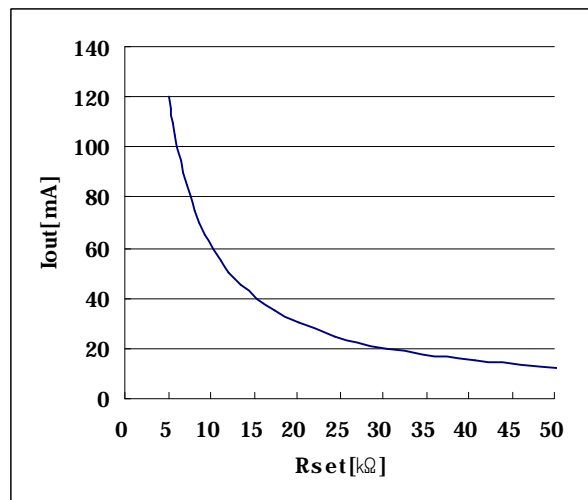

IOUt vs. Rset

Electrical Characteristics Curves

$V_{DD} = 12V$, $V_{OUT} = 2V$, $T_a = -35^{\circ}C \sim +85^{\circ}C$, unless otherwise specified. Typical values are at $T_A = +25^{\circ}C$

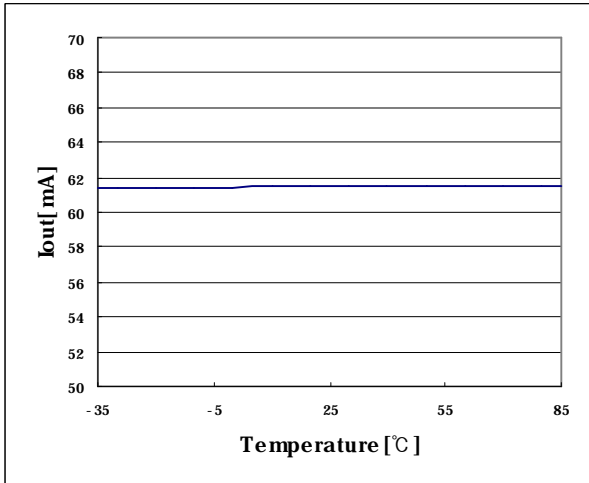

I_{OUT} vs. Temp

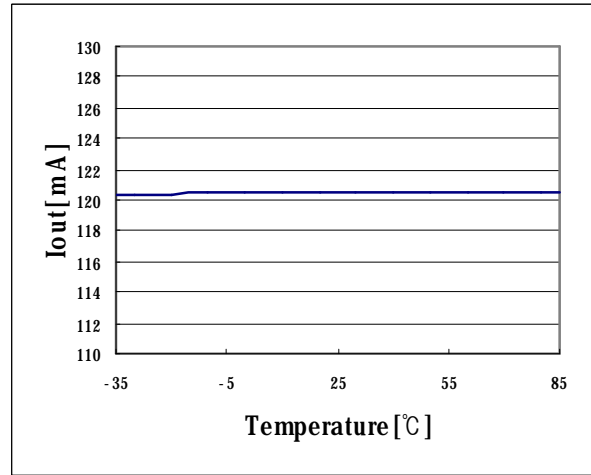

I_{OUT} vs. Temp

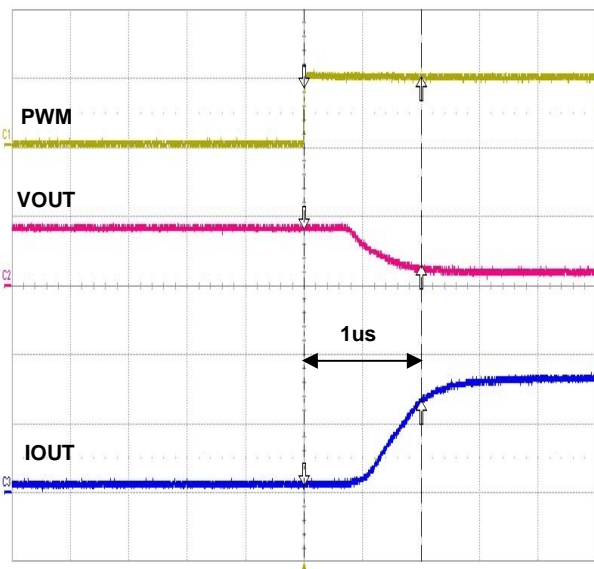

PWM Rising Time

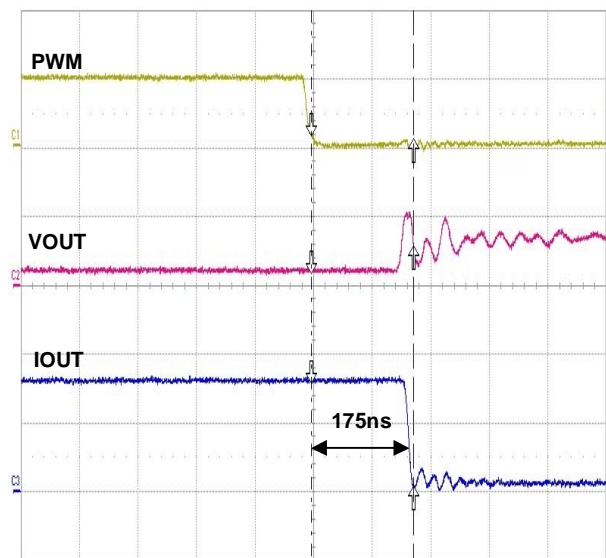

PWM Falling Time

Typical Applications

※ LED VF = 3.3V, IF = 20mA

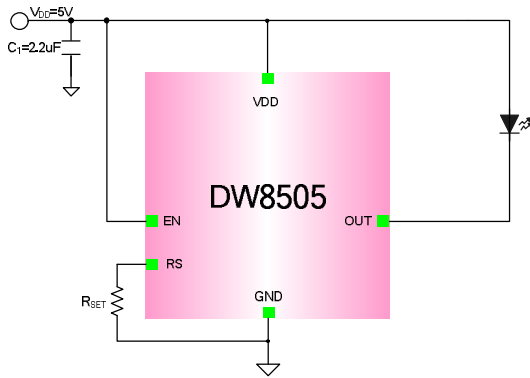

Figure 1. VDD=5V

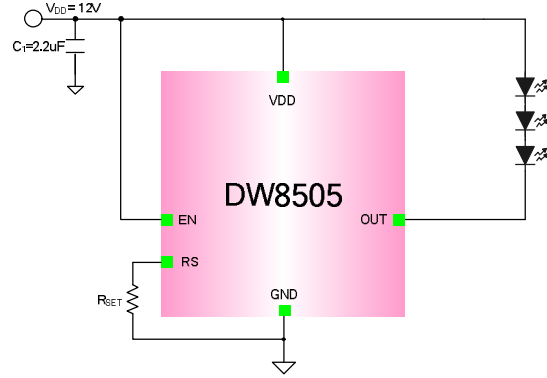

Figure 2. VDD=12V

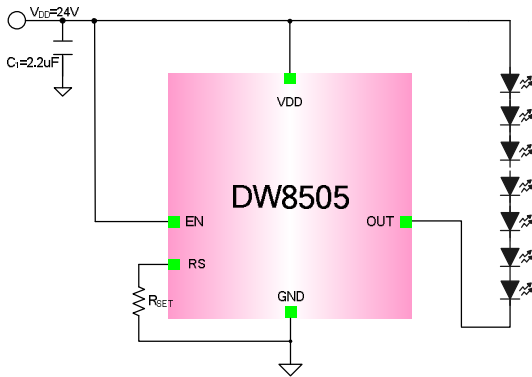

Figure 3. VDD=24V

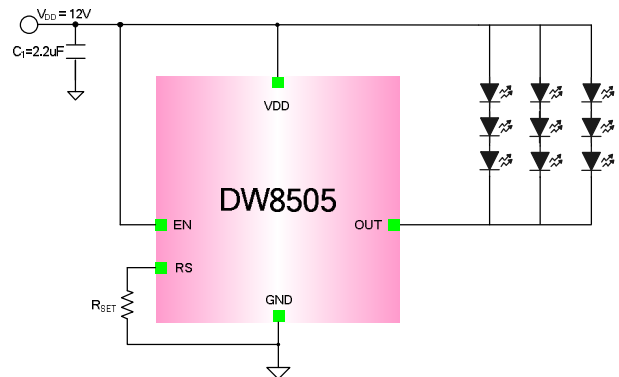

Figure 4. VDD=12V, 9 LED

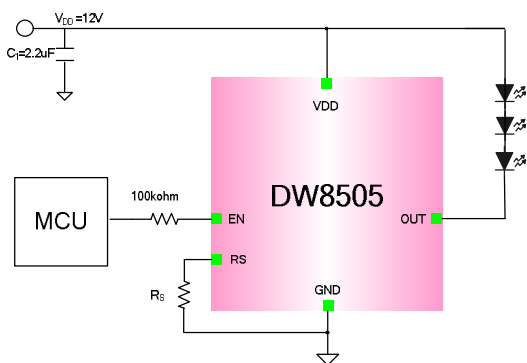

Figure 5. PWM Typical Application

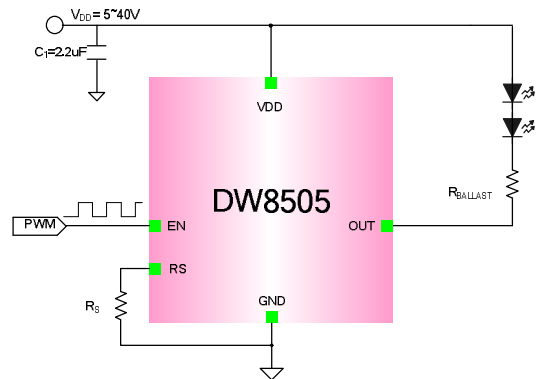
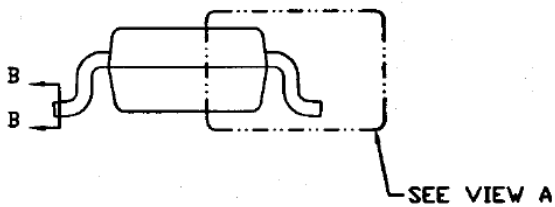
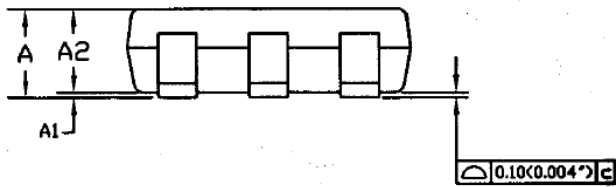
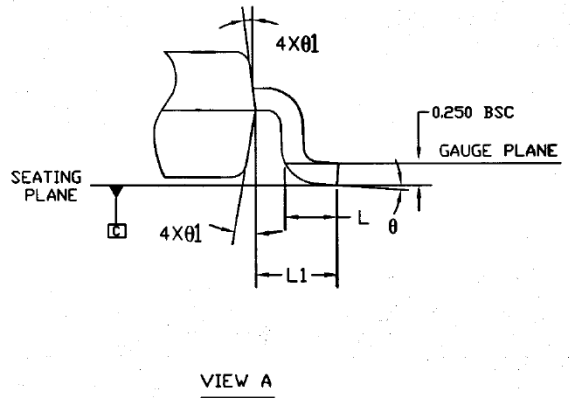
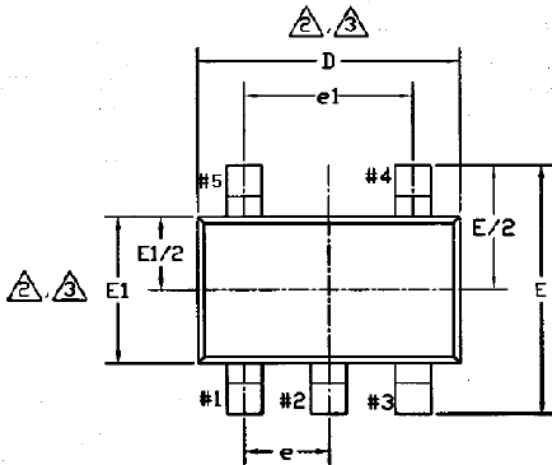

Figure 6. R_{VALLAST} Application

Package Dimension (TSV-5L 2.95 x 2.8 x 1)



SYMBOL	SPECIFICATION		
	DIMENSIONS MILLIMETER		
	MIN.	NOM.	MAX.
A	0.913	1.00	1.10
A1	0.013	0.05	0.10
A2	0.90	0.95	1.00
b	0.30	-	0.50
b1	0.30	0.35	0.40
c	0.135	-	0.20
c1	0.12	0.15	0.16
D	2.90	2.95	2.975
E	2.70	2.80	2.90
E1	1.525	1.60	1.675
e	0.95 BSC		
e1	1.90 BSC		
L	0.30	0.40	0.60
L1	0.60 REF.		
θ	0°	4°	8°
θ1	4°	10°	12°

Foot Print

