

QUARTZ CRYSTAL UNIT

SERIES 7U, SEAM SEALED CERAMIC 3.2*2.5MM SURFACE MOUNT PACKAGE



| |
|--------------|
| Approved by: |
| Checked by: |
| Issued by: |

SPECIFICATION

MODEL: SJK-7U-12.00-18-30-80-C-30

深圳市晶科鑫实业有限公司

SHENZHEN CRYSTAL TECHNOLOGY INDUSTRIAL CO., LTD.

Add: RM#1805, East Wing, TianAn Hi-tech Plaza Phase2, TianAn Cyber Park Shenzhen, China

Tel: (86) 755 88352809 88352810 Fax: (86) 755 88353718 88352499

E-mail: jolly@q-crystal.com HTTP://www.q-crystal.com

QUARTZ CRYSTAL UNIT



SERIES 7U, SEAM SEALED CERAMIC 3.2*2.5MM SURFACE MOUNT PACKAGE

FEATURE

- I Ultra thin, thickness 1.0mm
- I Leadless type
- I High precision characteristic covering up to high frequency range
- I Designed for automatic mounting and reflow soldering
- I Embossed taping specification
- I The best choice of Bluetooth wireless communication sets, DSN, PDA and mobile phone

ELECTRICAL SPECIFICATIONS

| | |
|--|------------------|
| Output Frequency Range | 12.00 MHz |
| Mode | AT/Fundamental |
| Frequency Tolerance (at 25°C) | ±30ppm |
| Frequency Stability Over Operating Temperature Characteristics | ±30ppm |
| Operating Temperature Range | -40 °C to +85 °C |
| Storage Temperature Range | -40 °C to +85 °C |
| Shunt Capacitance (C ₀) | 5.0 PF Max |
| Driver Level (Typical) | 100μW |
| Load Capacitance(C _L) | 18 PF |
| Equivalent Series Resistance(ESR) | 80 Ω Max |
| Aging @25°C 1 st year (Max) | ±3ppm/year |

REMARK: SPECIFICATIONS SUBJECT TO CHANGE WITHOUT PRIOR NOTICE.
PLEASE CONFIRM WITH OUR SALES ENGINEER.

Add: RM#1805, East Wing, TianAn Hi-tech Plaza Phase2, TianAn Cyber Park Shenzhen, China
Tel: (86) 755 88352809 88352810 Fax: (86) 755 88353718 88352499
E-mail: jolly@q-crystal.com HTTP://www.q-crystal.com

QUARTZ CRYSTAL UNIT

SERIES 7U, SEAM SEALED CERAMIC 3.2*2.5MM SURFACE MOUNT PACKAGE



Dimension

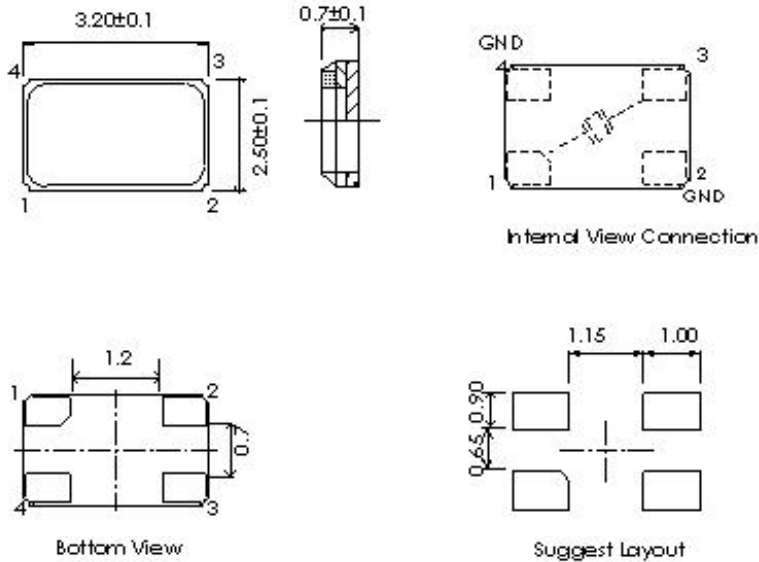

Units:mm

Reflow Condition

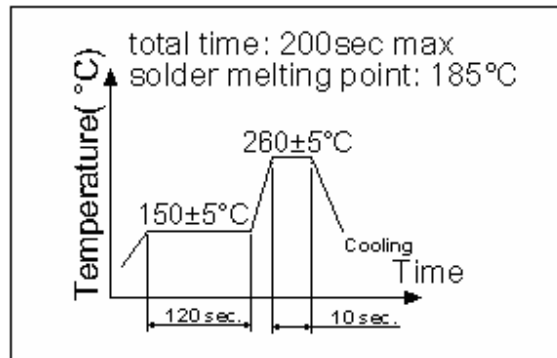

PART NUMBER

| | | | | | | |
|---------|---|---|--|--------------------------------|---|---|
| SJK-7U- | 12.000M | 18 | 30 | 80 | C | 30 |
| | Frequency e.g. 12.000: 12.000MHz | Load capacitance e.g. 18:18pF s: series | Frequency tolerance e.g. 30: ±30ppm | E.S.R.Max e.g. 80:80Ωmax | Operating temperature range A:-10-60°C B:-20-70°C C:-40-85°C | Temperature stability: e.g. 10: ±10ppm |

Add: RM#1805, East Wing, TianAn Hi-tech Plaza Phase2, TianAn Cyber Park Shenzhen, China

Tel: (86) 755 88352809 88352810 Fax: (86) 755 88353718 88352499

E-mail: jolly@q-crystal.com HTTP://www.q-crystal.com

QUARTZ CRYSTAL UNIT

SERIES 7U, SEAM SEALED CERAMIC 3.2*2.5MM SURFACE MOUNT PACKAGE



PACKING

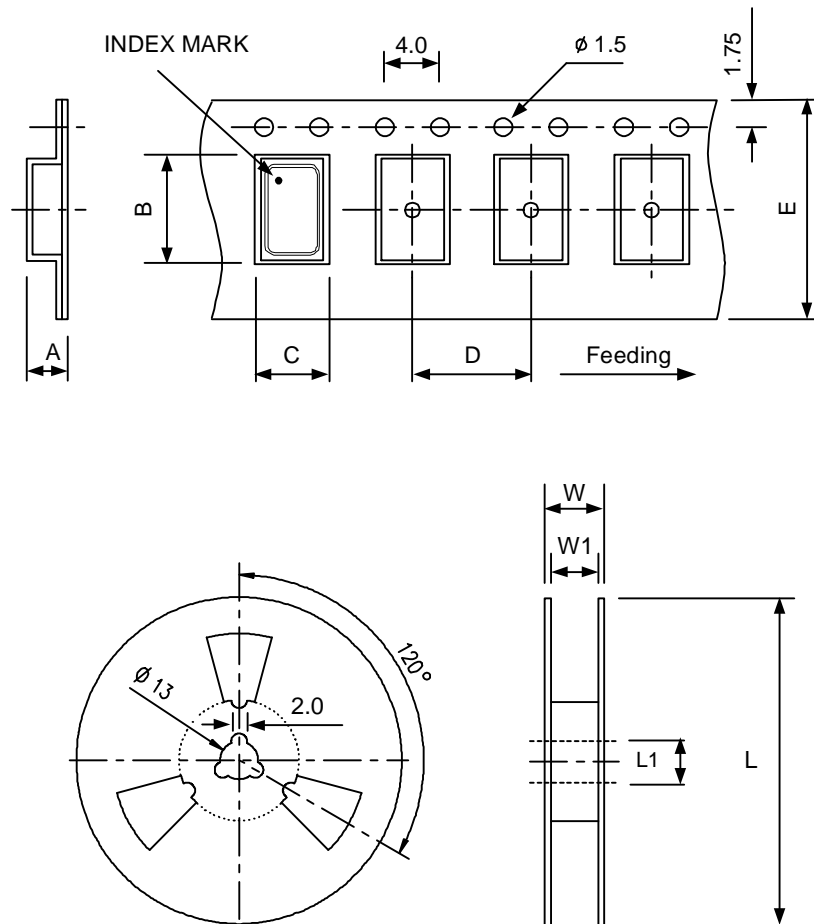

| DIMENSIONS | | A | B | C | D | E | L | L1 | W | W1 | pcs / Reel |
|------------|------|------|------|-----|-----|-----|-----|-----|------|------|------------|
| | 7050 | | 2.15 | 7.9 | 5.4 | 8.0 | 16 | 180 | 13 | 21.5 | 17.5 |
| 6035 | | 1.4 | 6.4 | 3.9 | 8.0 | 12 | 180 | 13 | 15.4 | 13 | |
| 5032 | | 1.46 | 5.5 | 3.6 | 8.0 | 12 | 180 | 13 | 15.4 | 13 | |
| 4025 | | 1.5 | 4.4 | 8.0 | 2.8 | 13 | 176 | 13 | 13.5 | 12 | |
| 3225 | | 1.4 | 3.4 | 2.7 | 4 | 8 | 178 | 13 | 11.5 | 8 | |

Add: RM#1805, East Wing, TianAn Hi-tech Plaza Phase2, TianAn Cyber Park Shenzhen, China
 Tel: (86) 755 88352809 88352810 Fax: (86) 755 88353718 88352499
 E-mail: jolly@q-crystal.com HTTP://www.q-crystal.com

QUARTZ CRYSTAL UNIT

SERIES 7U, SEAM SEALED CERAMIC 3.2*2.5MM SURFACE MOUNT PACKAGE



RELIABILITY TEST SPECIFICATION

| Test item | Equipment | Condition | Specification |
|-----------------------------------|---|---|--------------------------------|
| 1. SOLDERABILITY TEST | TBAEI ESPEC(K-1425-14D) | Welding can be temperature: 260 ± 5 °C, 5' s(125 °C, 120 SEC preheating Anti-welding temperature: 260 ± 5 °C, soaking time: 10 seconds | MIL-STD-883E Method 2003.7 |
| 2. HERMETICITY TEST | Helium leak detectors | 1. Small leak: 4.5 KGF/CM2 2hours1 * 10-9-9 PA.M3/SEC crude leak: 4.5KGF/CM2 2hours1.5 * 10-5 PA.M3/SEC | MIL-STD-883E Method 1014.10 |
| 3. VIBRATION TEST | Sweep vibration test machines (IMV CO. (VS-300-2)), S & A250B | 1 Crystal on 10-2000 Hz, X, Y, Z water level, each 20-minute vibration, a test every four hours, then the sample used to test 250 b | MIL-STD-883E Method 2007.3 |
| 4. MECHANICAL SHOCK | TOOL | A high degree of crystal from 150 CM to 150 g of three directions from the direction of impact X.Y.Z3 work hard wooden board | JIS C6701 |
| 5. MECHANICAL IMPACT TEST | TOOL | c1000G, 0.5Msec, 3, from the X, Y, Z three-day direction of hard wood boards, then the sample used to test 250 B | MIL-STD-202F Method 213B |
| 6. DROP TEST | Fell hard wood equipment, S & A 250B | Crystal 75 cm in height, falling three times in the hard wooden board | JIS C6701 |
| 7. SALT SPRAY | H-SST-60、RC-328A | 5% NaCl (sodium carbonate), 35 ± 2 °C temperature of the box, 48 hours, PH value: 6.5 to 7.2 | |
| 8. HIGH&LOW TEMP STORAGE TEST | TABEL ESPEC(MC-810), S&A 350B/250B | High temperature: 125 ± 2 °C, 500 hours; low temperature: -40 ± 3 °C, 500hours | MIL-STD-883E Method 1005.8 |
| 9. TEMP& HUM CYCLING TEST | TABEL ESPEC (TPC-211) S&A350B/250B | Temperature: $121 + / -3$ °C RH100% 2BAI, 240hours | JIS C6701 |
| 10. HIGH TEM. & HUM. STORAGE TEST | TBAEL ESPEC (PH-3F) , S&A350B/250B | Temperature: 40 ± 2 , Humidity: 85 +3, -2%, storage 96 hours | JIS C5023 |
| 11. AGING TEST | PRA(2360) | Temperature: 85 ± 3 °C, 1000hours | JIS C6701 |

Add: RM#1805, East Wing, TianAn Hi-tech Plaza Phase2, TianAn Cyber Park Shenzhen, China

Tel: (86) 755 88352809 88352810 Fax: (86) 755 88353718 88352499

E-mail: jolly@q-crystal.com HTTP://www.q-crystal.com