

| | |
|--------------|--|
| Approved by: | |
| Checked by : | |
| Issued by: | |

SPECIFICATION

MODEL: SJK-6B-3.579545-16-30-120-F-B-30-H

深圳市晶科鑫实业有限公司
SHENZHEN CRYSTAL TECHNOLOGY INDUSTRIAL CO., LTD.

Add: RM#:1805East Wing, TianAn Hi-tech Plaza Phase2, TianAn Cyber Park, Shenzhen, China
Tel: (86) 755 88352809 88352810 Fax: (86) 755 88353718 88352499
E-mail: jolly@q-crystal.com HTTP://www.q-crystal.com

FEATURE

- Height 3.5mm, The volume is compact at about one –fourth of the former product(HC-49U)
- A resistance weld completely sealed type
- The frequency stability is good ,the reliability is high
- Copes with high density mounting and is the is the optimum for mass production

ELECTRICAL SPECIFICATIONS

| | |
|--|---|
| Nominal frequency | 3.579545MHz |
| Oscillation mode | Fundamental |
| Load capacitance | 16PF |
| Frequency tolerance | $\pm 30\text{PPM}$ at $25 \pm 3^\circ\text{C}$ |
| Equivalent series resistance | 120 Ω |
| Storage temperature range | $-40^\circ\text{C} \text{---} +85^\circ\text{C}$ |
| Operating temperature range | $-20^\circ\text{C} \text{---} +70^\circ\text{C}$ |
| Frequency Stability Over Operating Temperature | $\pm 30\text{PPM}$ |
| Parallel capacitance(Co) | 7PF Max |
| Drive level | 10 μW |
| Insulation resistance | More than 500M Ω AT DC100V |
| Shock Resistace | Drop test of 3times on 2mm stainless plate from 75cm height |

Quartz Crystal



Series 6B, Resistance Welded HC-49/S Package

Dimension

HC-49S

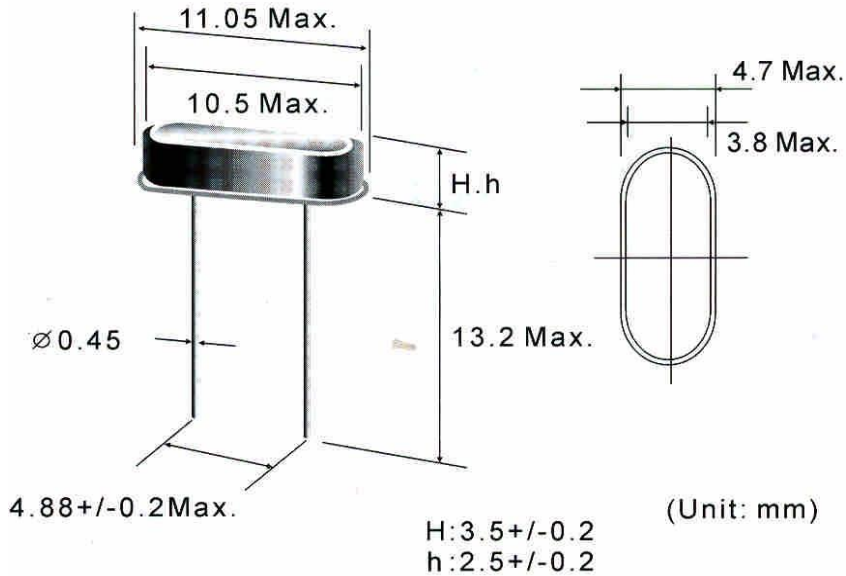

Wave soldering temperature curve

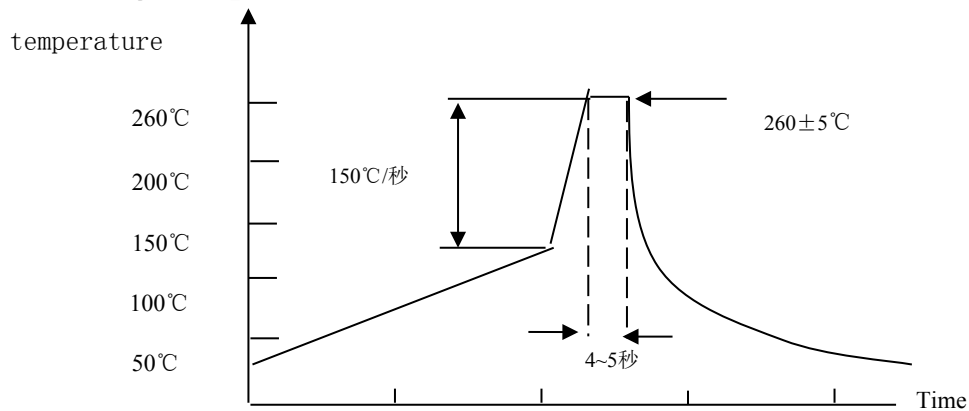

PART NUMBER

| | | | | | | | |
|------------------------------|---|----------------------------------|------------------------------|--|---|-------------------------------------|---|
| SJK-3.579545 | 16 | 30 | 120 | F | B | 30 | H |
| 6B- Frequency 3.579545MHz | Load capacitance 16pf s:series | Frequency tolerance ±30ppm | E.S.R.max e.g. 120Ωmax | oscillate mode F:Fundamental 3:3rd overtone 5:5th overtone | operating temperature range A:-10-60°C B:-20-70°C C:-40-85°C | temperature stability: ±30ppm | H:Normal (3.5mm) h:low (2.5mm) |

Add: RM#:1805East Wing, TianAn Hi-tech Plaza Phase2, TianAn Cyber Park, Shenzhen, China

Tel: (86) 755 88352809 88352810 Fax: (86) 755 88353718 88352499

E-mail: jolly@q-crystal.com HTTP://www.q-crystal.com

Quartz Crystal

Series 6B, Resistance Welded HC-49/S Package



RELIABILITY TEST SPECIFICATION

| Test item | Equipment | Condition | Specification |
|--|--|---|--|
| 1. TERMINAL STRENGTH TEST | Pull equipment | 1.10N FORCE IN AXES OF TERMINATION 10±1SEC 2.2.5MM FROM TERMINAL, BEND 90° | '1. MIL-STD-202F,METHOD 211A |
| 2.SOLDERABILITY TEST | SJK-REL001、RC-328A | 1.solderability:235±5°C, 5±0.5S 2.heat resistance:260±5°C,10±1S restoration of 1 hour | '1. MIL-STD-883CMETHOD 2003.7 2. MIL-STD-202F,METHOD 210A |
| 3. HERMETICITY TEST | UL-306S | small and do not control roughly (hubble-bubble machine); Nothing air bubble creation s thin leave out 1 * 10 E-8 ATM.CC/SEC. | MIL-STD-883C METHOD 1014.9 |
| 4. VIBRATION TEST | HG-V4、S&A 250B | Enable Crystal(10g) from 10-55-10Hz,X、Y、Z horizontal,1 Minute vibration/time, 1time/ 2 hours. | JIS C5025 TEST A MIL-STD-883C,METHOD 2007.2 |
| 5. MECHANICAL SHOCK | HPC-200、S&A 250B | Enable Crystal 50G(490m/s ²) time=11 ms speed=3.4 m/s half sine wave oscillation | JIS C5026 MIL-STD-883C,METHOD 2002 |
| 6. DROP TEST | HARD BOARD.S&A250B | 75CM HIGH,3 TIMES ON HARD BOARD | 'JIS C6701 |
| 7. SALT SPRAY | H-SST-60、RC-328A | 5% NaCL,35°C±2°C CHAMBER,48 hrs., PH:6.5~7.2 | JIS C5028 & MIL-STD-202F'METHOD 101D |
| 8. HIGH&LOW TEMP STORAGE TEST(Static test) | H-PTH-80CK & HM101-3ABN, S&A 350B/250B | High temperature: 125°C±2°C,1000hr; Low temperature:-40°C±3°C,1000hrs | MIL-STD-883C,METHOD 1011.8& JIS C5030 |
| 9. TEMP & HRM CYCLING TEST | H-PTH-80CK CHAMBER, S&A 350B/250B | Temperature:-10°C±2°C~65°C±2°C, Humidity:93±3%,1 cycle need 24 hrs. 5cycles. | MIL-STD-883C,METHOD 1010.7 |
| 10. HIGH TEM. & HUM. STORAGE TEST | H-PTH-80CK CHAMBER, S&A350B /250B | temperature:40°C±2, Humidity:85+3,-2%,Store 96 hrs | JIS C5023 |
| 11. AGING TEST | H-PTH-80CK CHAMBER, S&A350B /250 | temperature: 85°C±2, 1000hrs | JIS C5031 |

Add: RM#:1805East Wing,TianAn Hi-tech Plaza Phase2,TianAn Cyber Park, Shenzhen, China

Tel: (86) 755 88352809 88352810 Fax: (86) 755 88353718 88352499

E-mail: jolly@q-crystal.com HTTP://www.q-crystal.com