



ROHS

# Specification

Client Name : \_\_\_\_\_

Client P/N : \_\_\_\_\_

Factory P/N : HL-PETA-3010H203BC

Sending Date : \_\_\_\_\_

Client approval			Hong li approval		
Approval	Audit	Confirmation	Approval	Audit	Confirmation
			殷小平		谭娅
<input type="checkbox"/> Qualified <input type="checkbox"/> Unqualified			DATE: _____		

Adr : West side of Dongfeng Highway, Auto City, Huadu  
District, Guangzhou, China  
Tel : 020-86733333 (Switchboard)  
Fax : 020-86733883 86733938 86733265  
Web : [www.honglitronic.com](http://www.honglitronic.com)

## HL-PETA-3010H203BC

### Features

- Extremely wide viewing angle
- Suitable for all SMT assembly and solder process
- Available on tape and reel
- Moisture sensitivity level: Level 4
- Package:3000pcs/reel
- RoHS compliant

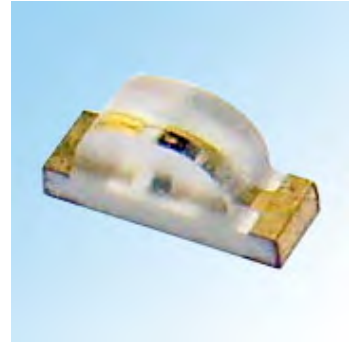

### Description

The Blue source color devices are made with InGaN on Substrate Light Emitting Diode

### Applications

- Optical indicator
- Indoor display
- Interior automotive lighting
- Backlight for LCD, switch and Symbol, display
- Light pipe application
- General use



**ATTENTION**  
OBSERVE PRECAUTIONS  
FOR HANDLING  
ELECTROSTATIC  
DISCHARGE  
SENSITIVE  
DEVICES

### Package Dimensions

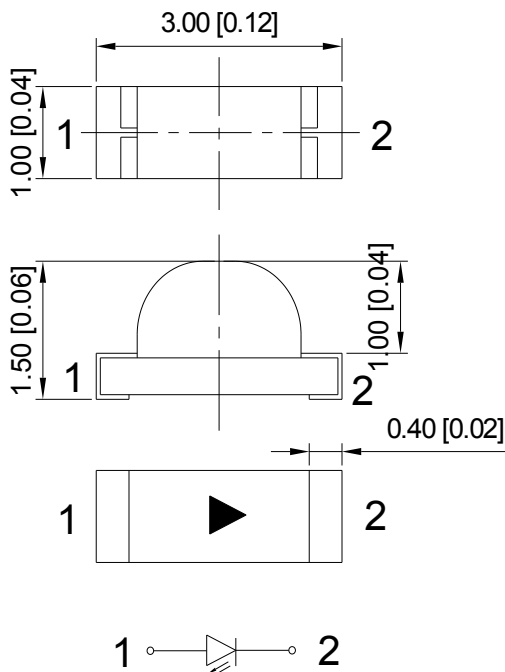

### Recommended Soldering

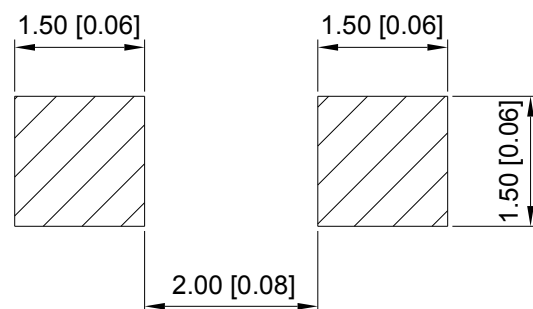

#### Notes:

1. All dimension units are millimeters.
2. All dimension tolerance is  $\pm 0.15$ mm unless otherwise noted.

## HL-PETA-3010H203BC

### Selection Guide

Part No.	Dice	Lens Type	Luminous intensity (mcd) @ 20mA		Viewing Angle
			Min.	TYP.	2θ1/2
HL-PETA-3010H203BC	Blue (InGaN)	Water Clear	90	125	140°

Note:

1. θ1/2 is the angle from optical centerline where the luminous intensity is 1/2 the optical centerline value.
2. the above luminous intensity measurement allowance tolerance ±10%.

### Electrical / Optical Characteristics at Ta=25°C

Parameter	Symbol	Min.	Typ.	Max.	Units	Test Conditions
Forward Voltage	V <sub>F</sub>	2.8	--	3.4	V	I <sub>F</sub> =20mA
Reverse Current	I <sub>R</sub>	--	--	10	μA	V <sub>R</sub> = 5V
Dominate Wavelength	λ <sub>d</sub>	464	--	474	nm	I <sub>F</sub> =20mA

### Absolute Maximum Ratings at Ta=25°C

Parameter	Symbol	Value	Units
Power Dissipation	P <sub>d</sub>	105	mW
DC Forward Current	I <sub>F</sub>	30	mA
Peak Forward Current [1]	I <sub>FP</sub>	100	mA
Reverse Voltage	V <sub>R</sub>	5	V
Electrostatic Discharge (HBM)	ESD	1000	V
Operating Temperature	T <sub>opr</sub>	-40 ~ +85	°C
Storage Temperature	T <sub>stg</sub>	-40 ~ +100	°C

Note:

1. 1/10 Duty Cycle, 0.1ms Pulse Width.

# HL-PETA-3010H203BC

## Typical optical characteristics curves

Ambient Temperature VS. Forward Current

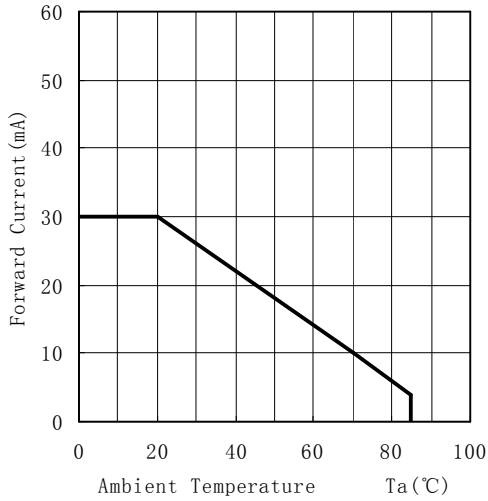

Forward Current VS. Relative Intensity

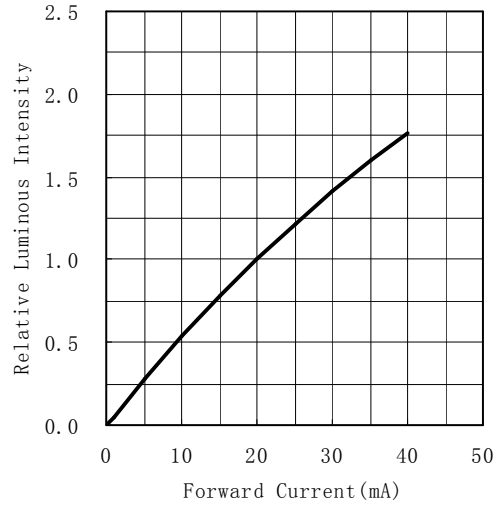

Forward Voltage VS. Forward Current

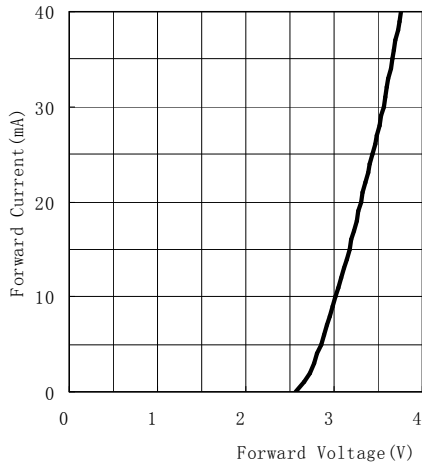

Ambient Temperature VS. Relative Intensity

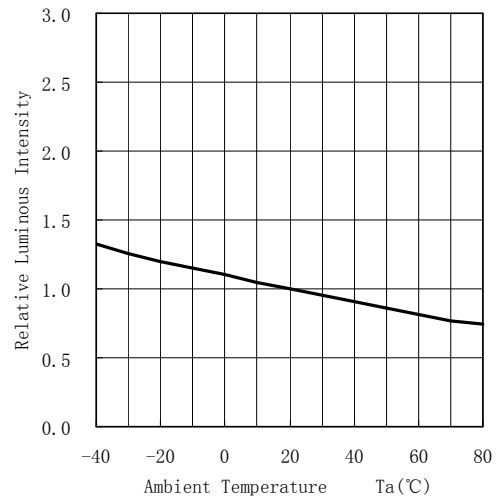

Relative spectral emission

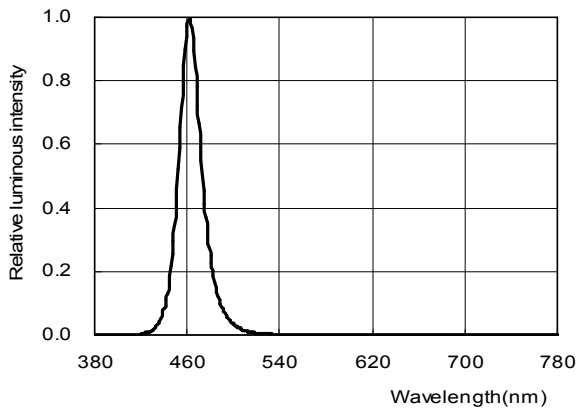
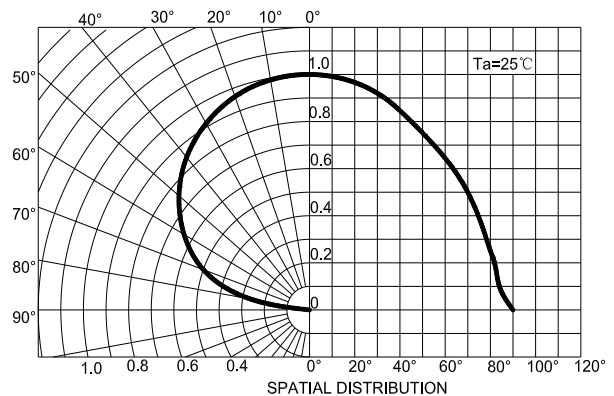

Diagram characteristics of radiation



## HL-PETA-3010H203BC

### Reliability Test Items And Conditions

The reliability of products shall be satisfied with items listed below.  
 Confidence level :90%  
 LTPD :10%

No.	Items	Ref.Standard	Test Condition	Test Hours/ Cycles	Sample Size	Ac/Re
1	Reflow	JESD22-B106	Temp:260°Cmax T=10 sec	3 times.	22Pcs.	0/1
2	Temperature Cycle	JESD22-A104	100°C±5°C 30 min. ↑↓5 min -40°C±5°C 30 min.	100 Cycles	22Pcs.	0/1
3	Thermal Shock	JESD22-A106	100°C±5°C 5 min. ↑↓ -40°C±5°C 5 min.	100 Cycles	22Pcs.	0/1
4	High Temperature Storage	JESD22-A103	Temp:100°C±5°C	1000Hrs.	22Pcs.	0/1
5	Low Temperature Storage	JESD22-A119	Temp:-40°C±5°C	1000Hrs.	22Pcs.	0/1
6	DC Operating Life	JESD22-A108	Ta=25°C±5°C IF=20mA	1000Hrs.	22Pcs.	0/1
7	High Temperature High Humidity	JESD22-A101	85°C±5°C/ 85%RH IF=5mA	1000Hrs.	22Pcs.	0/1

\*The technical information shown in the data sheets are limited to the typical characteristics and circuit examples of the referenced products. It does not constitute the warranting of industrial property nor the granting of any license.

## HL-PETA-3010H203BC

### SMT Reflow Soldering Instructions

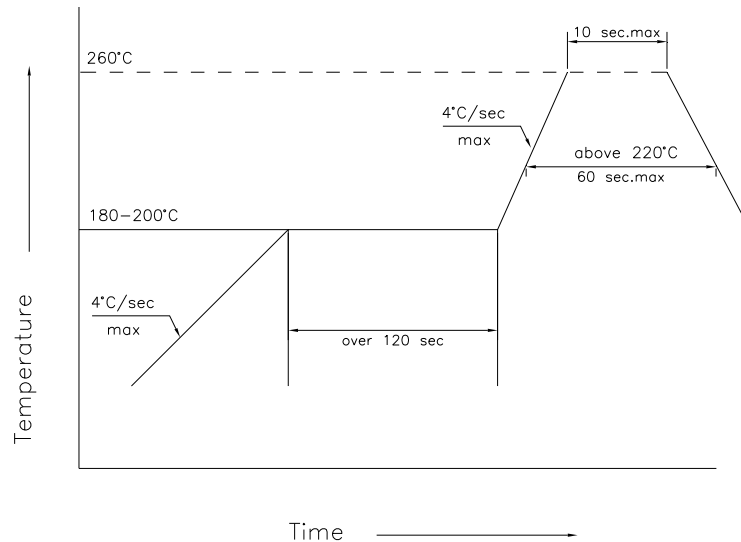

1. Reflow soldering should not be done more than two times
2. When soldering, do not put stress on the LEDs during heating

### Soldering iron

1. When hand soldering, the temperature of the iron must be less than 300°C for 3 seconds
2. The hand solder should be done only one time

### Repairing

Repair should not be done after the LEDs have been soldered. When repairing is unavoidable, a double-head soldering iron should be used (as below figure). It should be confirmed beforehand whether the characteristics of LEDs will or will not be damaged by repairing.

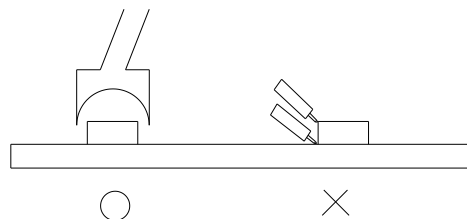

### Cautions

The encapsulated material of the LEDs is silicone. Therefore the LEDs have a soft surface on the top of the package. The pressure applied to the top surface will influence the reliability of the LEDs. Precautions should be taken to avoid strong pressure on the encapsulated part. So when using a picking up nozzle, the pressure on the silicone resin should be proper.

# HL-PETA-3010H203BC

## Label

IV: Luminous intensity rank  
 $\lambda$ D: Dominate Wavelength  
 VF: Forward voltage rank



## Tape Specifications (Units : mm)

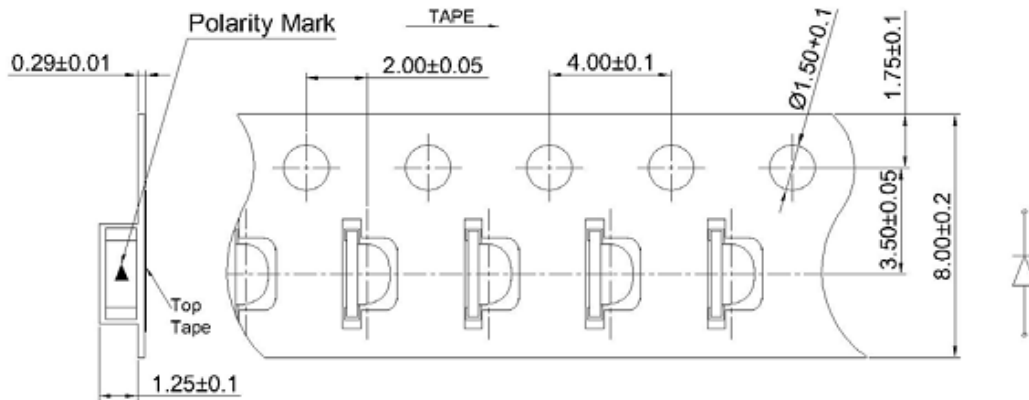

## Reel Dimensions

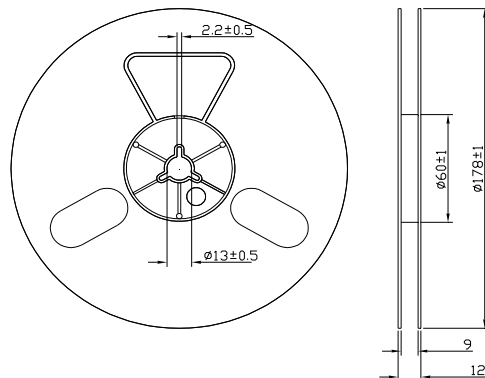

## Moisture Resistant Packaging

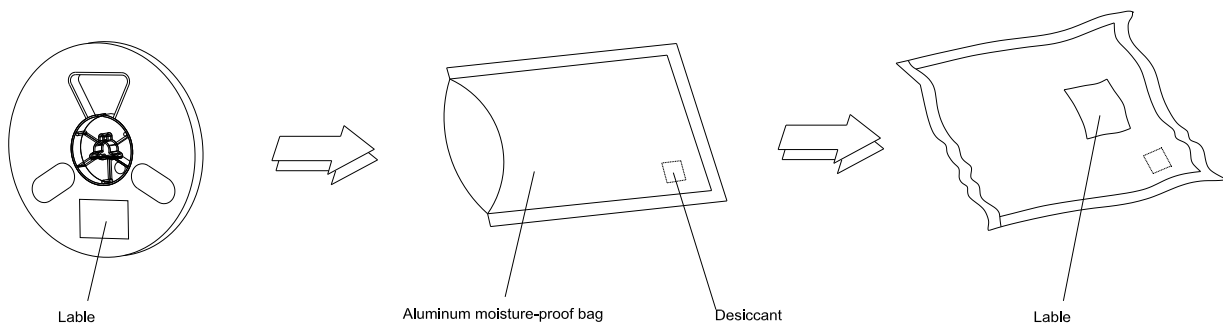

Note: The tolerances unless mentioned is  $\pm 0.1$ mm, Unit: mm