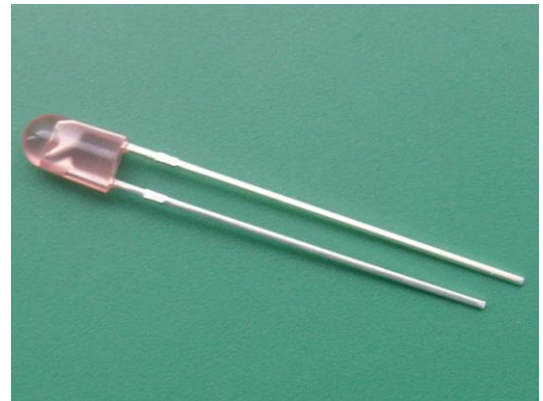

ATTENTION
 OBSERVE PRECAUTIONS
 FOR HANDLING
 ELECTROSTATIC
 DISCHARGE
 SENSITIVE
 DEVICES

HL-293U4FD

Features

- φ 4 LAMP LED
- LOW POWER CONSUMPTION.
- WIDE VIEWING ANGLE.
- IDEAL FOR BACKLIGHT AND INDICATOR.
- PACKAGE: 1000PCS / BAG.

Description

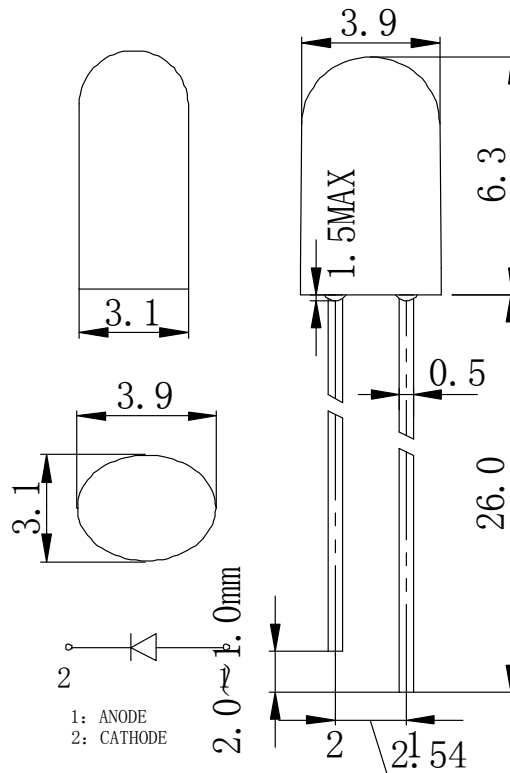
This devices are made with AlGaInP.

Package Dimensions

Tolerance Grade	Dimension Torlerance (UNIT:mm)			
	0.5~3	3~6	6~30	30~120
	±0.1	±0.2	±0.3	±0.5
Chip		Lens Color		
Material	Emitting Color	Color Diffused		
AlGaInP	Red			

■ Absolute Maximum Rating

Item	Symbol	Value	Unit
Forward Current	I_F	20	mA
Peak Forward Current*	I_{FP}	100	mA
Reverse Voltage	V_R	5	V
Power Dissipation	P_D	80	mW
Electrostatic discharge	E_{SD}	2000	V
Operation Temperature	T_{opr}	-40~+100	°C
Storage Temperature	T_{stg}	-40~+100	°C
Lead Soldering Temperature*	T_{sol}	Max. 260°C for 5sec Max.	

* I_{FP} Conditions: Pulse Width ≤ 10 msec

* T_{sol} Conditions: 3mm from the base of the epoxy bulb

■ Typical Optical/ Electrical Characteristics $T_a=25^\circ\text{C}$

Item	Symbol	Condition	Rank	Min.	Typ.	Max.	Unit
Luminous Intensity	I_v	$I_F=20\text{mA}$	M	210		276	mcd
			N	276		355	mcd
			O	355		460	mcd
Forward Voltage	V_F			1.8	2.2	2.6	V
Viewing Angle	2θ 1/2			--	100/X 60/Y	--	deg
Dominant Wavelength	λ_D			620	--	630	nm
Recommend Forward Current	$I_F(\text{rec})$	--		--	--	20	mA
Reverse Current	I_R	$V_r=5\text{V}$		--	--	20	μA

Notes:

Tolerance : $V_F \pm 0.1\text{V}$, $\lambda_d \pm 2\text{ nm}$, $I_V(\phi V) \pm 15\%$, 2θ 1/2 $\pm 15\%$

■ Reliability Performance
Test Items And Result

Test Classification	Test Item	Test Conditions	Test Duration	Sample Size	AC/RE
Life Test	Room Temperature DC Operating Life Test	$T_a=25^{\circ}\text{C}\pm 5^{\circ}\text{C}$, $I_f=20\text{mA}$	1000 hrs	22 pcs	0/1
Environment Test	Thermal Shock Test	$100^{\circ}\text{C}\pm 5^{\circ}\text{C}$ 5min ↑ ↓ $-40^{\circ}\text{C}\pm 5^{\circ}\text{C}$ 5min.	100 cycles	22 pcs	0/1
	Temperature Cycle Test	$100^{\circ}\text{C}\pm 5^{\circ}\text{C}$ 30min ↑ ↓ 5min $-40^{\circ}\text{C}\pm 5^{\circ}\text{C}$ 30min.	100 cycles	22 pcs	0/1
	High Temperature & High Humidity Test	$85^{\circ}\text{C}\pm 5^{\circ}\text{C}/85\% \text{RH}$ $I_f=5\text{mA}$	1000 hrs	22 pcs	0/1
	High Temperature Storage	$T_a=100^{\circ}\text{C}\pm 5^{\circ}\text{C}$	1000 hrs	22 pcs	0/1
	Low Temperature Storage	$T_a=-40^{\circ}\text{C}\pm 5^{\circ}\text{C}$	1000 hrs	22 pcs	0/1
Mechanical Test	Resistance to Soldering Heat	Temp= 260°C max T=5sec max	1times	22 pcs	0/1
	Lead Integrity	Load 2.5N(0.25kgf) $0^{\circ} \sim 90^{\circ} \sim 0^{\circ}$	3times	22 pcs	0/1

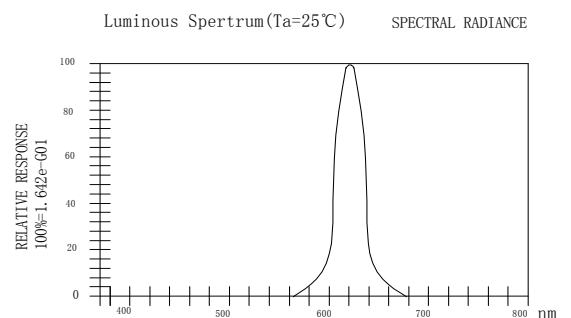
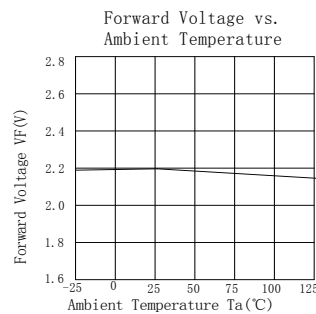
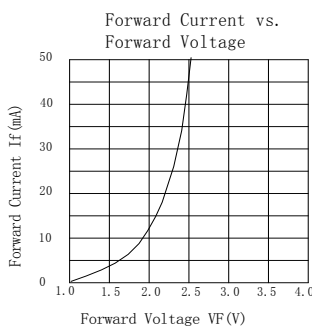
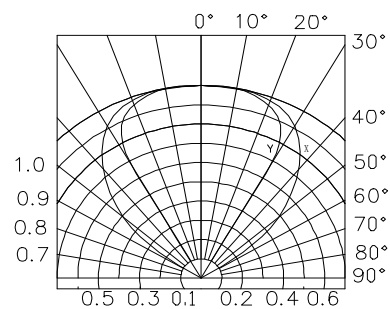
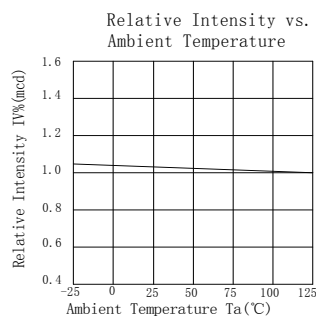
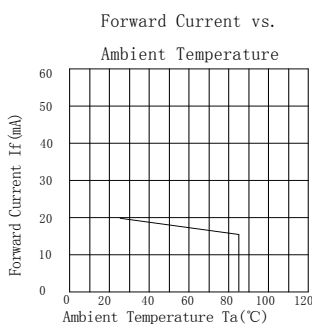

Soldering:

1. Manual Of Soldering

The temperature of the iron tip should not be higher than 300°C and Soldering within 3 seconds per solder-land is to be observed.

2. DIP soldering (Wave Soldering):

Preheating: 120°C~150°C, within 120~180 sec.

Operation heating: 245°C ± 5°C within 5 sec. 260°C (Max)

Gradual Cooling (Avoid quenching).

