

**GigaDevice Semiconductor Inc.**

**GD32470I-EVAL**

**User Guide**

**V2.0**

# Table of Contents

<b>TABLE OF CONTENTS</b> .....	<b>1</b>
<b>LIST OF FIGURES</b> .....	<b>4</b>
<b>LIST OF TABLES</b> .....	<b>5</b>
<b>1. SUMMARY</b> .....	<b>6</b>
<b>2. FUNCTION PIN ASSIGNMENT</b> .....	<b>6</b>
<b>3. GETTING STARTED</b> .....	<b>10</b>
<b>4. HARDWARE LAYOUT OVERVIEW</b> .....	<b>11</b>
<b>4.1. Power supply</b> .....	<b>11</b>
<b>4.2. Boot option</b> .....	<b>11</b>
<b>4.3. LED</b> .....	<b>11</b>
<b>4.4. KEY</b> .....	<b>12</b>
<b>4.5. USART</b> .....	<b>13</b>
<b>4.6. ADC</b> .....	<b>13</b>
<b>4.7. DAC</b> .....	<b>14</b>
<b>4.8. I2S</b> .....	<b>14</b>
<b>4.9. I2C</b> .....	<b>14</b>
<b>4.10. SPI</b> .....	<b>15</b>
<b>4.11. CAN</b> .....	<b>15</b>
<b>4.12. ENET</b> .....	<b>16</b>
<b>4.13. SDIO</b> .....	<b>16</b>
<b>4.14. NAND flash</b> .....	<b>17</b>
<b>4.15. SDRAM</b> .....	<b>17</b>
<b>4.16. DCI</b> .....	<b>18</b>
<b>4.17. LCD</b> .....	<b>18</b>
<b>4.18. USBFS</b> .....	<b>19</b>
<b>4.19. USBHS</b> .....	<b>19</b>
<b>4.20. Extension</b> .....	<b>20</b>
<b>4.21. GD-Link</b> .....	<b>20</b>
<b>5. ROUTINE USE GUIDE</b> .....	<b>21</b>
<b>5.1. GPIO_Running_LED</b> .....	<b>21</b>
5.1.1. DEMO purpose .....	21
5.1.2. DEMO running result .....	21
<b>5.2. GPIO_Key_Polling_mode</b> .....	<b>21</b>
5.2.1. DEMO purpose .....	21
5.2.2. DEMO running result .....	21
<b>5.3. EXTI_Key_Interrupt_mode</b> .....	<b>22</b>

5.3.1.	DEMO purpose .....	22
5.3.2.	DEMO running result .....	22
<b>5.4.</b>	<b>USART_Printf.....</b>	<b>22</b>
5.4.1.	DEMO purpose .....	22
5.4.2.	DEMO running result .....	22
<b>5.5.</b>	<b>USART_Echo_Interrupt_mode.....</b>	<b>23</b>
5.5.1.	DEMO purpose .....	23
5.5.2.	DEMO running result .....	23
<b>5.6.</b>	<b>USART_DMA.....</b>	<b>23</b>
5.6.1.	DEMO purpose .....	23
5.6.2.	DEMO running result .....	23
<b>5.7.</b>	<b>ADC_Temperature_Vrefint.....</b>	<b>24</b>
5.7.1.	DEMO purpose .....	24
5.7.2.	DEMO running result .....	24
<b>5.8.</b>	<b>ADC0_ADC1_Follow_up_mode.....</b>	<b>25</b>
5.8.1.	DEMO purpose .....	25
5.8.2.	DEMO running result .....	25
<b>5.9.</b>	<b>ADC0_ADC1_Regular_Parallel_mode.....</b>	<b>26</b>
5.9.1.	DEMO purpose .....	26
5.9.2.	DEMO running result .....	26
<b>5.10.</b>	<b>DAC_Output_Voltage_Value .....</b>	<b>27</b>
5.10.1.	DEMO purpose .....	27
5.10.2.	DEMO running result .....	27
<b>5.11.</b>	<b>I2C_EEPROM.....</b>	<b>27</b>
5.11.1.	DEMO purpose .....	27
5.11.2.	DEMO running result .....	28
<b>5.12.</b>	<b>SPI_QSPI_Flash .....</b>	<b>28</b>
5.12.1.	DEMO purpose .....	28
5.12.2.	DEMO running result .....	29
<b>5.13.</b>	<b>I2S_Audio_Player.....</b>	<b>30</b>
5.13.1.	DEMO purpose .....	30
5.13.2.	DEMO running result .....	31
<b>5.14.</b>	<b>EXMC_SDRAM.....</b>	<b>31</b>
5.14.1.	DEMO purpose .....	31
5.14.2.	DEMO running result .....	31
<b>5.15.</b>	<b>EXMC_SDRAM_DeepSleep.....</b>	<b>32</b>
5.15.1.	DEMO purpose .....	32
5.15.2.	DEMO running result .....	33
<b>5.16.</b>	<b>EXMC_NandFlash.....</b>	<b>35</b>
5.16.1.	DEMO purpose .....	35
5.16.2.	DEMO running result .....	35
<b>5.17.</b>	<b>SDIO_SDCardTest.....</b>	<b>35</b>
5.17.1.	DEMO purpose .....	35

---

5.17.2. DEMO running result .....	36
<b>5.18. CAN_Network .....</b>	<b>36</b>
5.18.1. DEMO purpose .....	36
5.18.2. DEMO running result .....	37
<b>5.19. RCU_Clock_Out .....</b>	<b>37</b>
5.19.1. DEMO purpose .....	37
5.19.2. DEMO running result .....	37
<b>5.20. CTC_Calibration .....</b>	<b>38</b>
5.20.1. DEMO purpose .....	38
5.20.2. DEMO running result .....	38
<b>5.21. PMU_sleep_wakeup .....</b>	<b>38</b>
5.21.1. DEMO purpose .....	38
5.21.2. DEMO running result .....	38
<b>5.22. RTC_Calendar .....</b>	<b>39</b>
5.22.1. DEMO purpose .....	39
5.22.2. DEMO running result .....	39
<b>5.23. TIMER_Breath_LED.....</b>	<b>39</b>
5.23.1. DEMO purpose .....	39
5.23.2. DEMO running result .....	39
<b>5.24. TLI_IPA.....</b>	<b>40</b>
5.24.1. DEMO purpose .....	40
5.24.2. DEMO running result .....	40
<b>5.25. DCI_OV2640.....</b>	<b>40</b>
5.25.1. DEMO purpose .....	40
5.25.2. DEMO running result .....	41
<b>5.26. TRNG_Get_Random.....</b>	<b>41</b>
5.26.1. DEMO purpose .....	41
5.26.2. DEMO running result .....	42
<b>5.27. ENET .....</b>	<b>42</b>
5.27.1. FreeRTOS_tcpudp.....	42
5.27.2. Raw_tcpudp.....	44
5.27.3. Raw_webserver .....	47
<b>5.28. USB_Device .....</b>	<b>49</b>
5.28.1. HID_Keyboard .....	49
5.28.2. MSC_Udisk.....	50
<b>5.29. USB_Host .....</b>	<b>52</b>
5.29.1. HID_Host .....	52
5.29.2. MSC_Host.....	55
<b>6. REVISION HISTORY .....</b>	<b>56</b>

## List of Figures

<b>Figure 4-1 Schematic diagram of power supply.....</b>	<b>11</b>
<b>Figure 4-2 Schematic diagram of boot option .....</b>	<b>11</b>
<b>Figure 4-3 Schematic diagram of LED function .....</b>	<b>11</b>
<b>Figure 4-4 Schematic diagram of Key function .....</b>	<b>12</b>
<b>Figure 4-5 Schematic diagram of USART0 function .....</b>	<b>13</b>
<b>Figure 4-6 Schematic diagram of ADC function.....</b>	<b>13</b>
<b>Figure 4-7 Schematic diagram of DAC function.....</b>	<b>14</b>
<b>Figure 4-8 Schematic diagram of I2S function .....</b>	<b>14</b>
<b>Figure 4-9 Schematic diagram of I2C function .....</b>	<b>14</b>
<b>Figure 4-10 Schematic diagram of SPI function.....</b>	<b>15</b>
<b>Figure 4-11 Schematic diagram of CAN function.....</b>	<b>15</b>
<b>Figure 4-12 Schematic diagram of Ethernet function .....</b>	<b>16</b>
<b>Figure 4-13 Schematic diagram of SDIO function.....</b>	<b>16</b>
<b>Figure 4-14 Schematic diagram of NAND flash function.....</b>	<b>17</b>
<b>Figure 4-15 Schematic diagram of SDRAM function .....</b>	<b>17</b>
<b>Figure 4-16 Schematic diagram of DCI function .....</b>	<b>18</b>
<b>Figure 4-17 Schematic diagram of LCD function .....</b>	<b>18</b>
<b>Figure 4-18 Schematic diagram of USBFS function .....</b>	<b>19</b>
<b>Figure 4-19 Schematic diagram of USBHS function.....</b>	<b>19</b>
<b>Figure 4-20 Schematic diagram of Extension Pin.....</b>	<b>20</b>
<b>Figure 4-21 Schematic diagram of GD-Link.....</b>	<b>20</b>

# List of Tables

<b>Table 2-1 Function pin assignment .....</b>	<b>6</b>
<b>Table 6-1 Revision history .....</b>	<b>56</b>

## 1. Summary

GD32470i-EVAL uses GD32F470IKH6 as the main controller. It uses Mini USB interface or DC-005 connector to supply 5V power. SWD, Reset, Boot, User button key, LED, CAN, I2C, I2S, USART, RTC, LCD, SPI, ADC, DAC, EXMC, CTC, SDIO, DCI, ENET, USBFS, USBHS, GD-Link and Extension Pins are also included. For more details please refer to GD32470i-EVAL-V1.0 schematic.

## 2. Function pin assignment

**Table 2-1 Function pin assignment**

Function	Pin	Description
LED	PE2	LED1
	PE3	LED2
	PF10	LED3
RESET		K1-Reset
KEY	PA0	K2-Wakeup
	PC13	K3-Tamper
	PB14	K4-User key
USART0	PA9	USART0_TX
	PA10	USART0_RX
ADC	PC3	ADC012_IN13
DAC	PA4	DAC_OUT0
I2C	PB6	I2C0_SCL
	PB7	I2C0_SDA
SPI	PG10	SPI5_IO2
	PG11	SPI5_IO3
	PG13	SPI5_SCK
	PG14	SPI5_MOSI
	PG12	SPI5_MISO
	PI8	SPIFlash_CS
I2S	PA6	I2S1_MCK
	PI1	I2S1_CK
	PI0	I2S1_WS
	PC1	I2S1_SD
CAN	PB8	CAN0_RX
	PB9	CAN0_TX
NAND Flash	PD4	EXMC_NOE

	PD5	EXMC_NWE
	PD6	EXMC_NWAIT
	PD7	EXMC_NCE1
	PD11	EXMC_A16
	PD12	EXMC_A17
	PD14	EXMC_D0
	PD15	EXMC_D1
	PD0	EXMC_D2
	PD1	EXMC_D3
	PE7	EXMC_D4
	PE8	EXMC_D5
	PE9	EXMC_D6
	PE10	EXMC_D7
SDRAM	PD14	EXMC_D0
	PD15	EXMC_D1
	PD0	EXMC_D2
	PD1	EXMC_D3
	PE7	EXMC_D4
	PE8	EXMC_D5
	PE9	EXMC_D6
	PE10	EXMC_D7
	PE11	EXMC_D8
	PE12	EXMC_D9
	PE13	EXMC_D10
	PE14	EXMC_D11
	PE15	EXMC_D12
	PD8	EXMC_D13
	PD9	EXMC_D14
	PD10	EXMC_D15
	PE0	EXMC_NBL0
	PE1	EXMC_NBL1
	PC5	EXMC_SDCKE0
	PG4	EXMC_BA0
	PG5	EXMC_BA1
	PG8	EXMC_SDCLK
	PG15	EXMC_SDNCAS
	PF11	EXMC_SDNRAS
	PC2	EXMC_SDNE0
	PH5	EXMC_SDNWE
	PF0	EXMC_A0
	PF1	EXMC_A1



	PF2	EXMC_A2
	PF3	EXMC_A3
	PF4	EXMC_A4
	PF5	EXMC_A5
	PF12	EXMC_A6
	PF13	EXMC_A7
	PF14	EXMC_A8
	PF15	EXMC_A9
	PG0	EXMC_A10
	PG1	EXMC_A11
	PG2	EXMC_A12
	SDIO	PD2
PC12		SDIO_CK
PC8		SDIO_D0
PC9		SDIO_D1
PC10		SDIO_D2
PC11		SDIO_D3
DCI	PB6	DCI_I2C0_SCL
	PB7	DCI_I2C0_SDA
	PA4	DCI_HSYNC
	PG9	DCI_VSYNC
	PA6	DCI_PIXCLK
	PA8	DCI_XCLK
	PB9	DCI_D7
	PB8	DCI_D6
	PD3	DCI_D5
	PC11	DCI_D4
	PC9	DCI_D3
	PC8	DCI_D2
	PC7	DCI_D1
	PC6	DCI_D0
LCD	PI3	LCD_Touch_PENIRQ
	PF9	LCD_SPI4_MOSI
	PF8	LCD_SPI4_MISO
	PF7	LCD_SPI4_SCK
	PF6	LCD_SPI4_NSS
	PB15	LCD_PWM_BackLight
	PH7	LCD_Touch_Busy
	PH2	LCD_R0
	PH3	LCD_R1
	PH8	LCD_R2

	PH9	LCD_R3
	PH10	LCD_R4
	PH11	LCD_R5
	PH12	LCD_R6
	PG6	LCD_R7
	PE5	LCD_G0
	PE6	LCD_G1
	PH13	LCD_G2
	PH14	LCD_G3
	PH15	LCD_G4
	PI0	LCD_G5
	PI1	LCD_G6
	PI2	LCD_G7
	PE4	LCD_B0
	PG12	LCD_B1
	PG10	LCD_B2
	PG11	LCD_B3
	PI4	LCD_B4
	PI5	LCD_B5
	PI6	LCD_B6
	PI7	LCD_B7
	PG7	LCD_CLK
	PI10	LCD_HSYNC
	PI9	LCD_VSYNC
	PF10	LCD_DE
Ethernet	PA1	ETH_RMII_REF_CLK
	PA2	ETH_MDIO
	PA7	ETH_RMII_CRSDV
	PG11	ETH_RMII_TXEN
	PG13	ETH_RMII_TXD0
	PG14	ETH_RMII_TXD1
	PC1	ETH_MDC
	PC4	ETH_RMII_RXD0
	PC5	ETH_RMII_RXD1
	PA8	CK_OUT0
USB_FS	PA9	USBFS_VBUS
	PA11	USBFS_DM
	PA12	USBFS_DP
USB_HS	PH4	USB_HS_ULPI_NXT
	PI11	USB_HS_ULPI_DIR
	PC0	USB_HS_ULPI_STP

	PA5	USB_HS_ULPI_CK
	PB5	USB_HS_ULPI_D7
	PB13	USB_HS_ULPI_D6
	PB12	USB_HS_ULPI_D5
	PB11	USB_HS_ULPI_D4
	PB10	USB_HS_ULPI_D3
	PB1	USB_HS_ULPI_D2
	PB0	USB_HS_ULPI_D1
	PA3	USB_HS_ULPI_D0

### 3. Getting started

The EVAL board uses Mini USB connector or DC-005 connector to get power DC +5V, which is the hardware system normal work voltage. Three kinds of different USB power supply which are USB\_FS, USB\_HS\_ULPI, GD-Link can be chosen through JP4. A J-Link tool or GD-Link on board is necessary in order to download and debug programs. Select the correct boot mode and then power on, the LED5 will turn on, which indicates that the power supply is OK.

There are Keil version and IAR version of all projects. Keil version of the projects are created based on Keil MDK-ARM 4.74 uVision4. IAR version of the projects are created based on IAR Embedded Workbench for ARM 7.40.2. In Firmware folder, Addon and Software Pack are used to add the devices, peripherals and others to IDE. During use, the following points should be noted:

1. If you use Keil uVision4 to open the project, install the GD32F4xx\_Addon.3.0.0.exe which is in \Library\Firmware to load the associated files.
2. If you use Keil uVision5 to open the project, there are two ways to solve the “Device Missing (s)” problem. One is to install GigaDevice.GD32F4xx\_DFP.3.0.0.pack which is in \Library\Firmware. In Project menu, select the Manage sub menu, click on the “Version Migrate 5 Format...” menu, the Keil uVision4 project will be converted to Keil uVision5 project. Then add “C:\Keil\_v5\ARM\Pack\ARM\CMSIS\4.2.0\CMSIS\Include” to C/C++ in Option for Target. The other is to install Addon directly. Select the installation directory of Keil uVision5 software, such as C:\Keil\_v5, in Destination Folder of Folder Selection. Select the corresponding device in Device of Option for Target and add “C:\Keil\_v5\ARM\Pack\ARM\CMSIS\4.2.0\CMSIS\Include” to C/C++ in Option for Target.
3. If you use IAR to open the project, install IAR\_GD32F4xx\_ADDON.3.0.0.exe which is in \Library\Firmware to load the associated files.

## 4. Hardware layout overview

### 4.1. Power supply

Figure 4-1 Schematic diagram of power supply

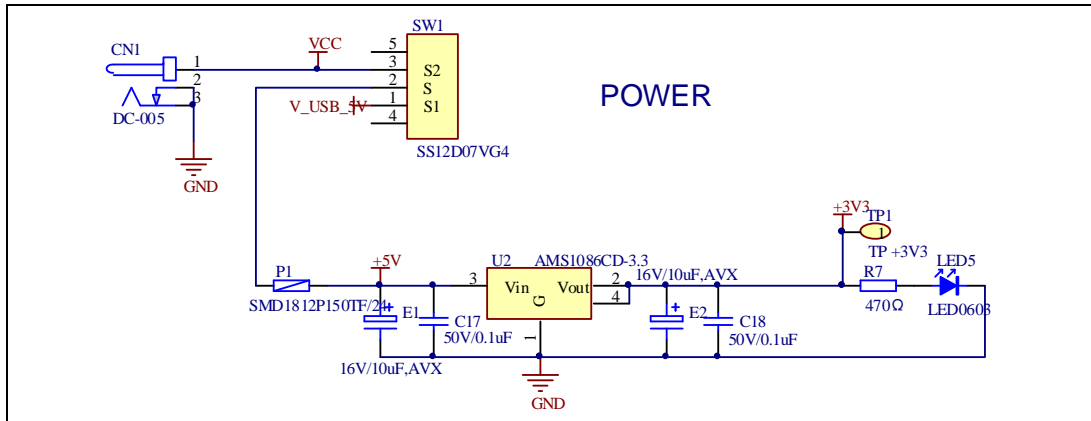

### 4.2. Boot option

Figure 4-2 Schematic diagram of boot option

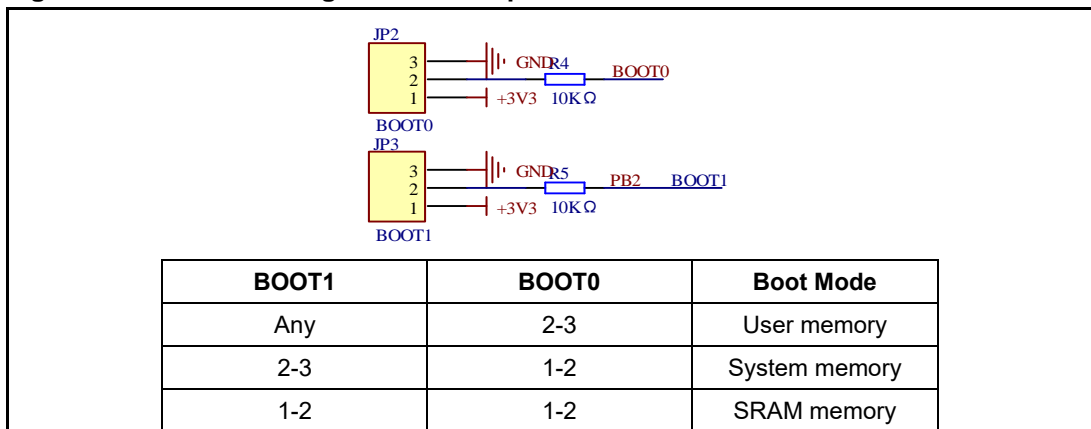

### 4.3. LED

Figure 4-3 Schematic diagram of LED function

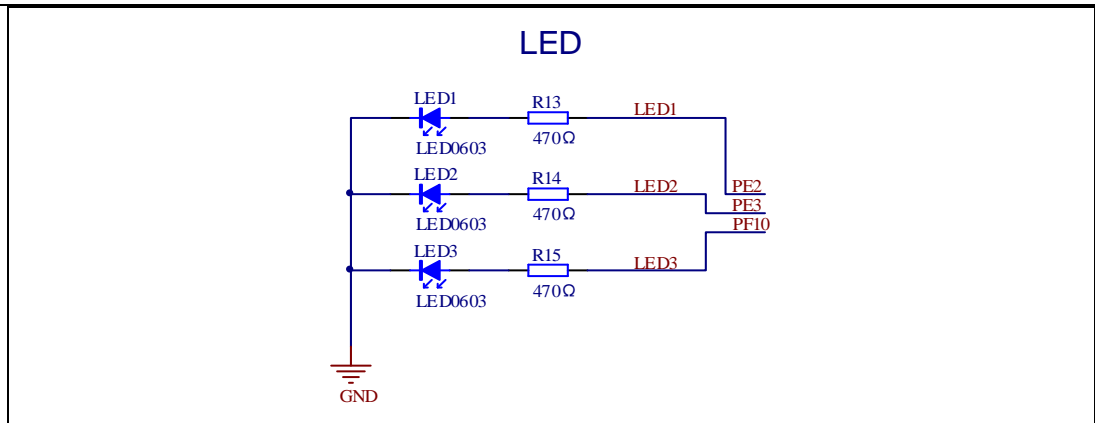

#### 4.4. KEY

Figure 4-4 Schematic diagram of Key function

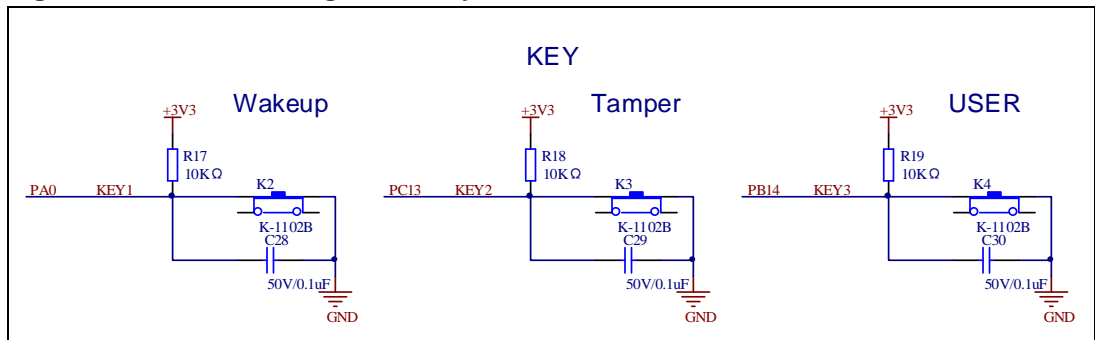

## 4.5. USART

Figure 4-5 Schematic diagram of USART0 function

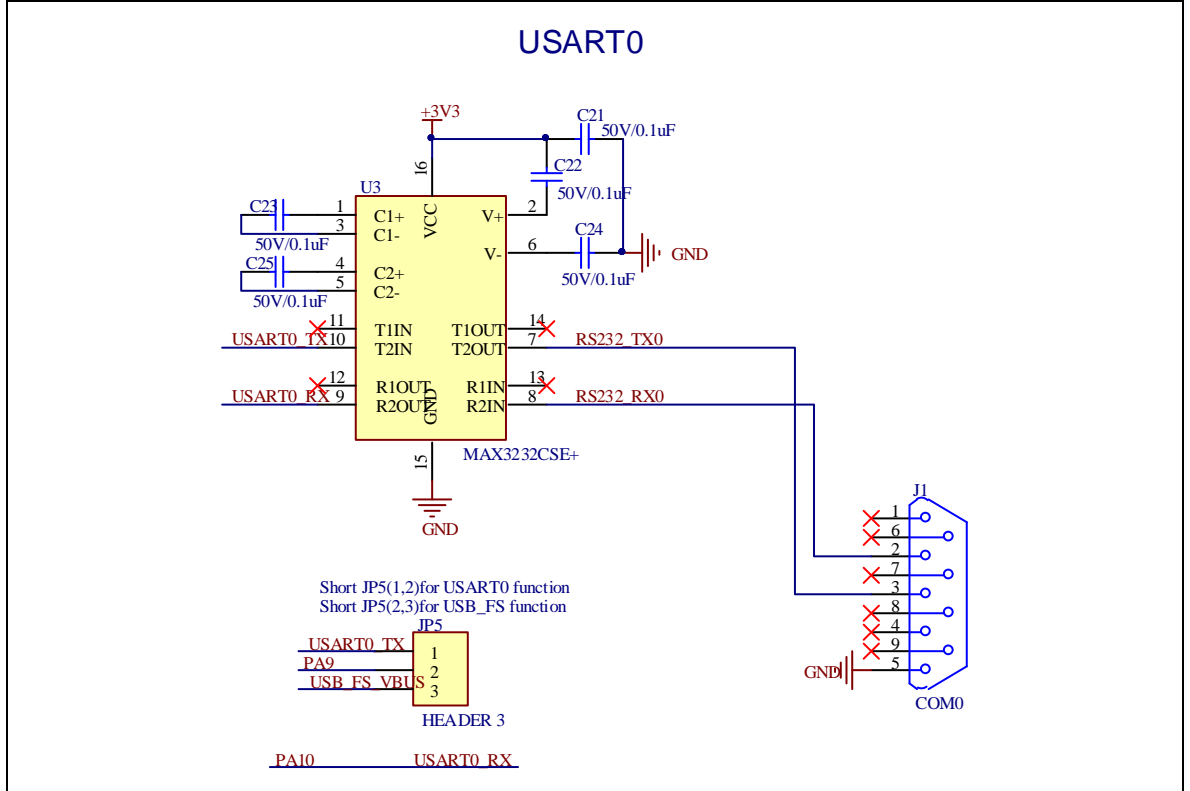

## 4.6. ADC

Figure 4-6 Schematic diagram of ADC function

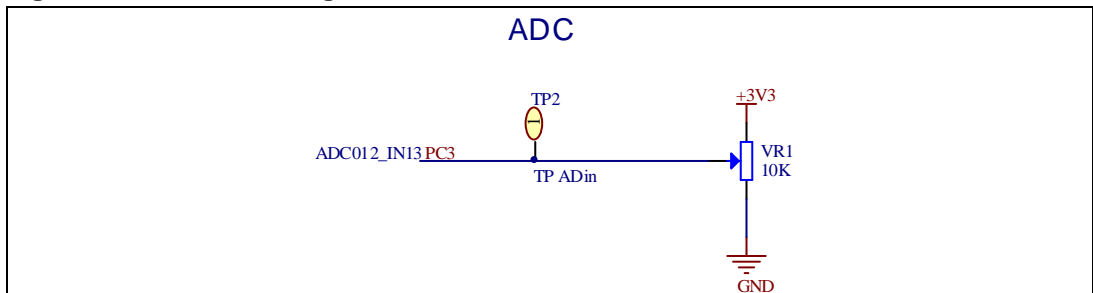

## 4.7. DAC

Figure 4-7 Schematic diagram of DAC function

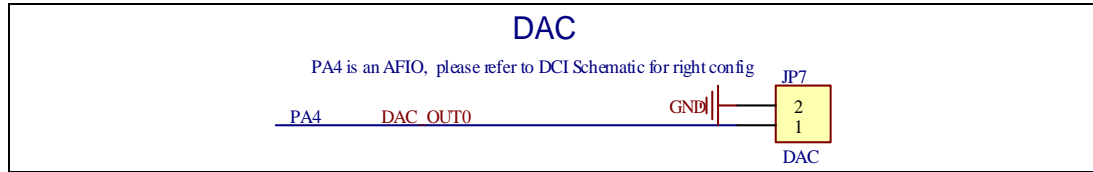

## 4.8. I2S

Figure 4-8 Schematic diagram of I2S function

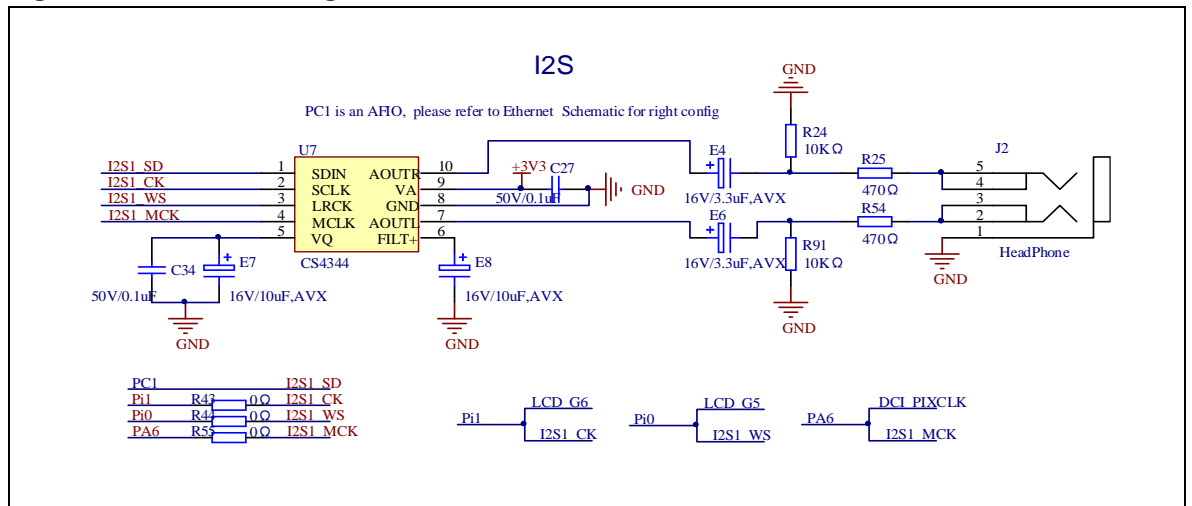

## 4.9. I2C

Figure 4-9 Schematic diagram of I2C function

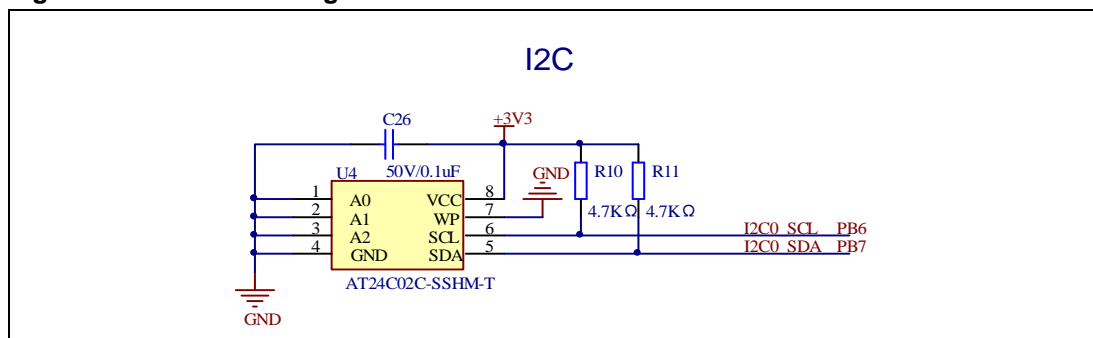

## 4.10. SPI

Figure 4-10 Schematic diagram of SPI function

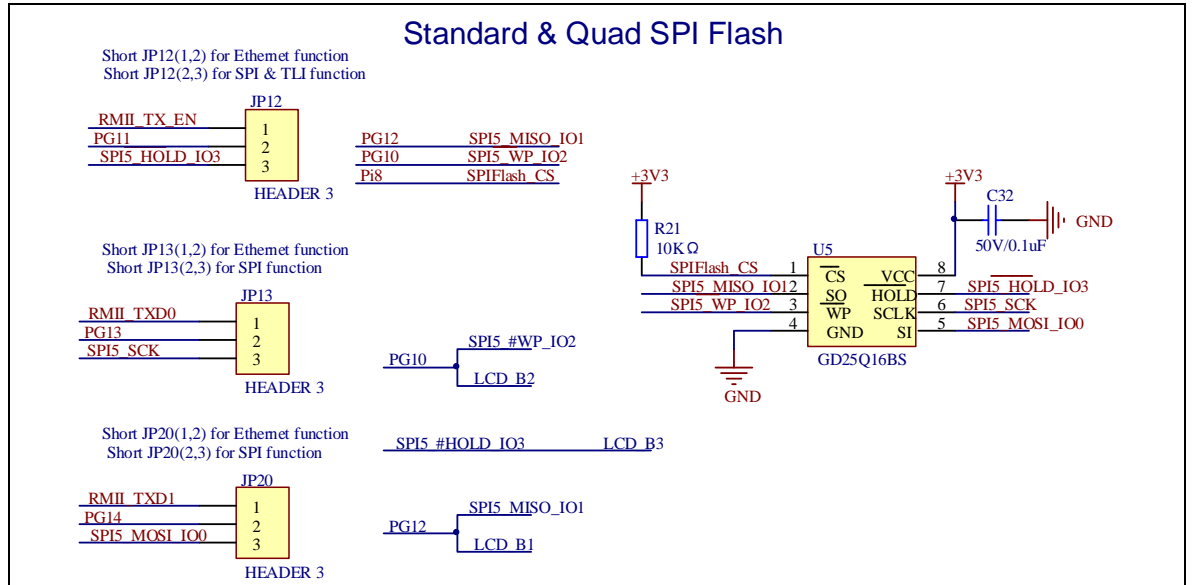

## 4.11. CAN

Figure 4-11 Schematic diagram of CAN function

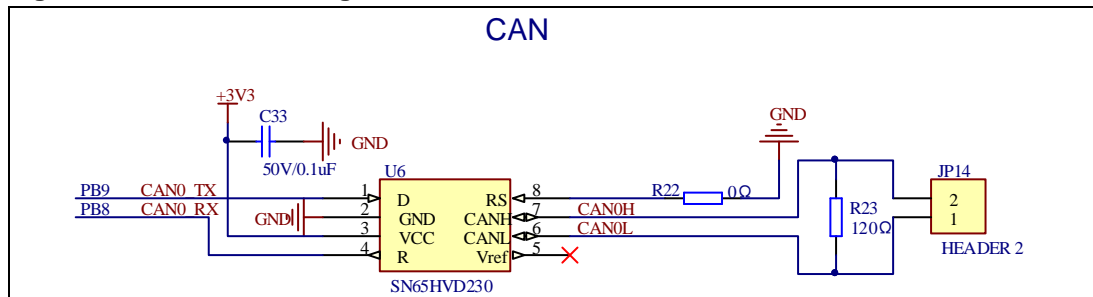



## 4.12. ENET

Figure 4-12 Schematic diagram of Ethernet function

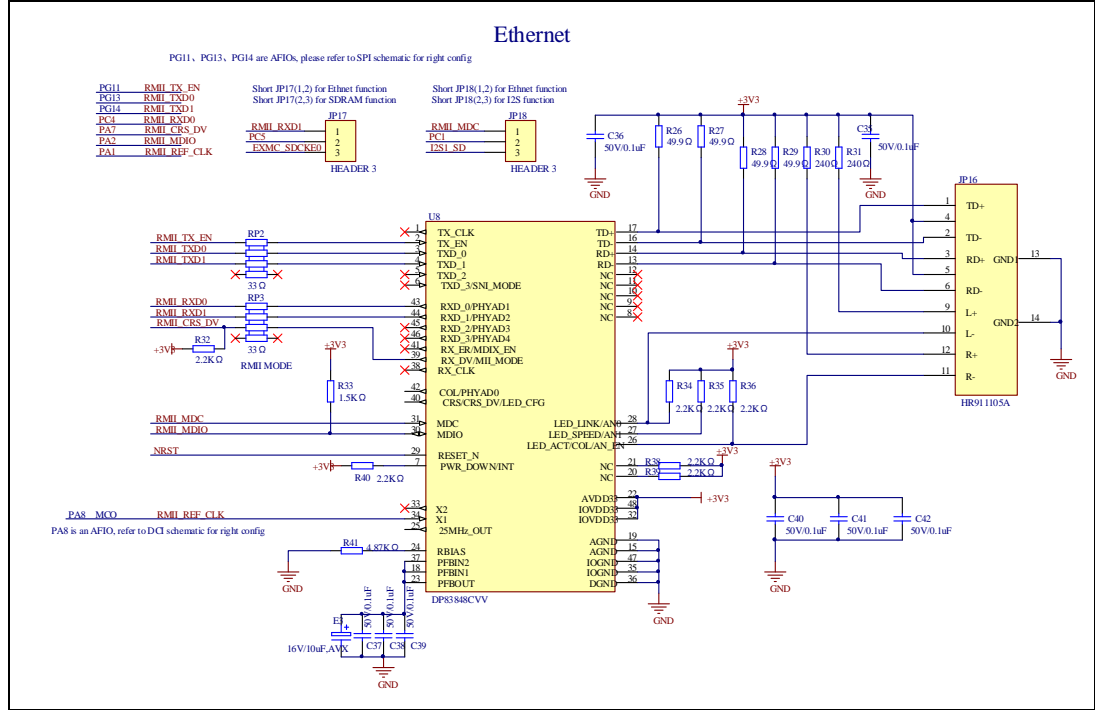

## 4.13. SDIO

Figure 4-13 Schematic diagram of SDIO function

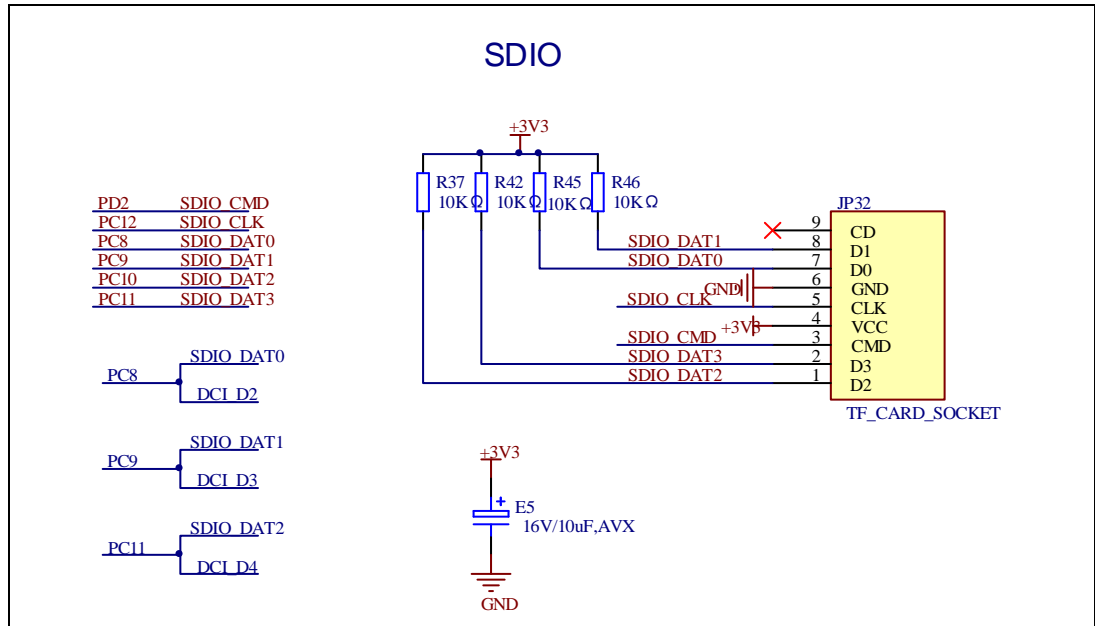

## 4.14. NAND flash

Figure 4-14 Schematic diagram of NAND flash function

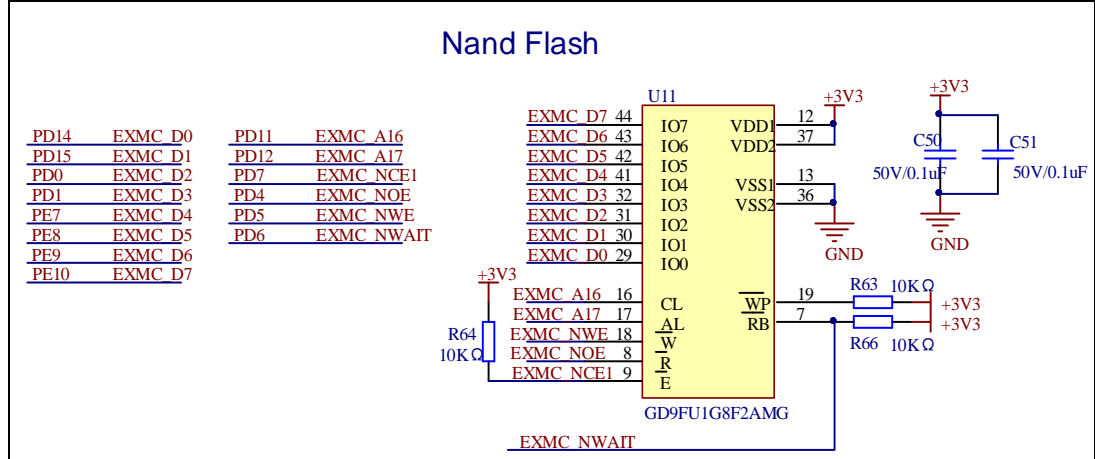

## 4.15. SDRAM

Figure 4-15 Schematic diagram of SDRAM function

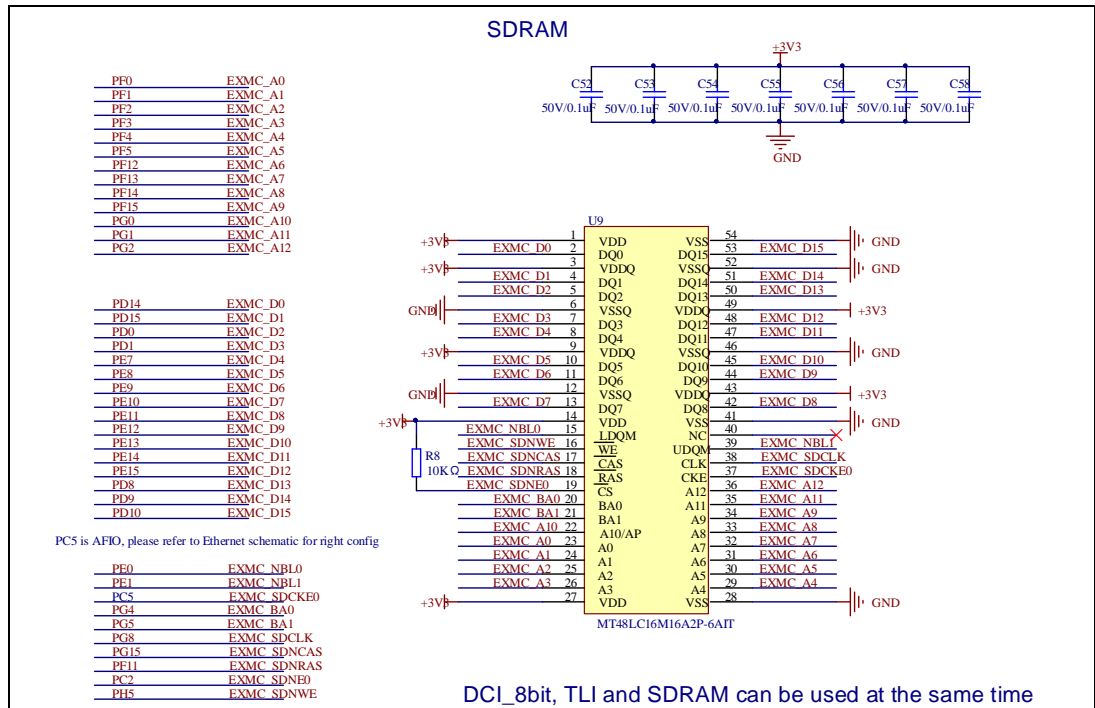

## 4.16. DCI

Figure 4-16 Schematic diagram of DCI function

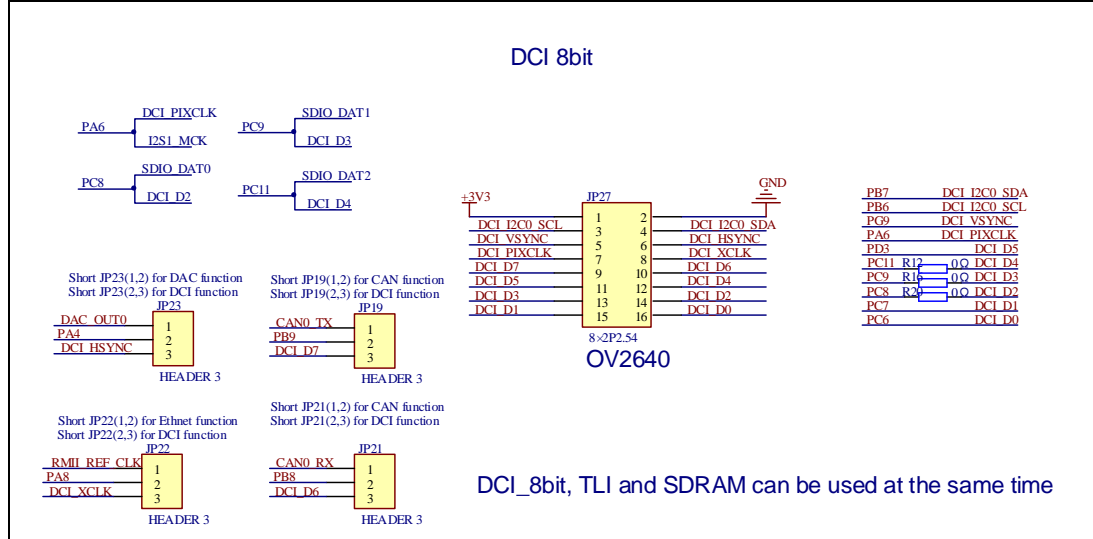

## 4.17. LCD

Figure 4-17 Schematic diagram of LCD function

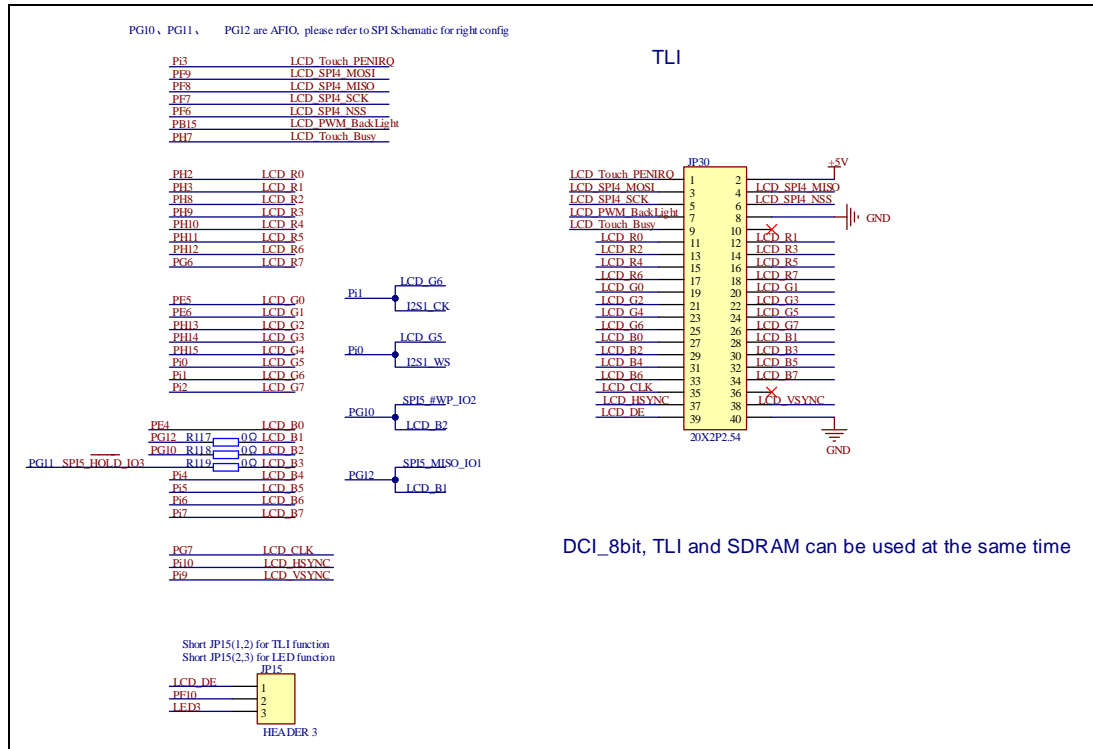



## 4.20. Extension

Figure 4-20 Schematic diagram of Extension Pin

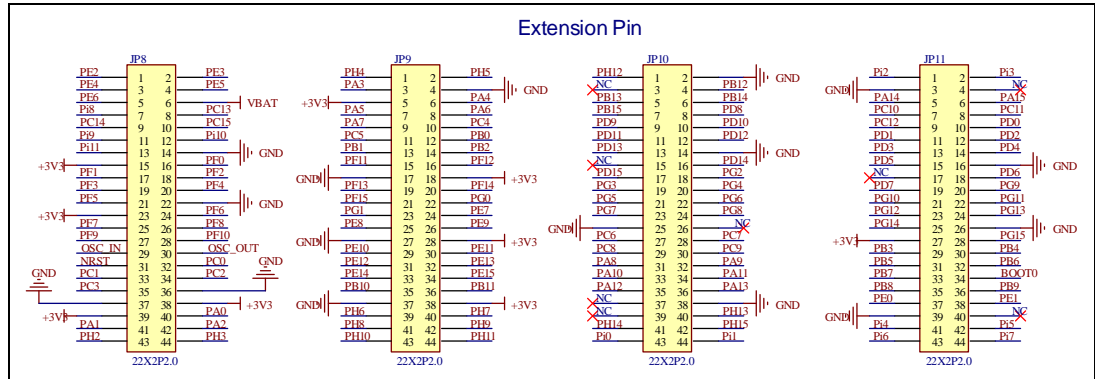

## 4.21. GD-Link

Figure 4-21 Schematic diagram of GD-Link

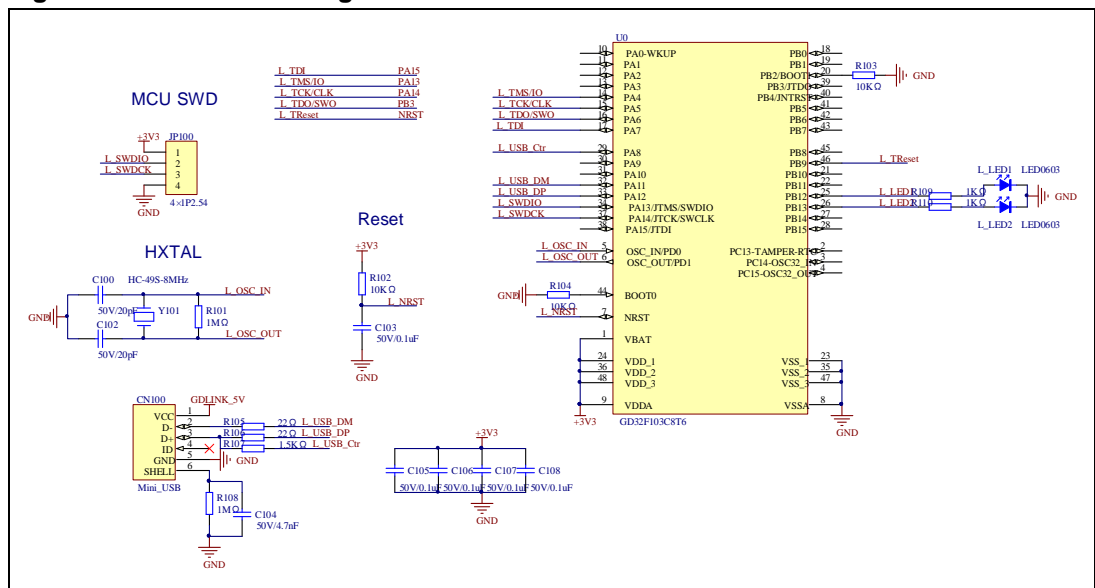

## 5. Routine use guide

### 5.1. GPIO\_Running\_LED

#### 5.1.1. DEMO purpose

This demo includes the following functions of GD32 MCU:

- Learn to use GPIO control the LED.
- Learn to use SysTick to generate 1ms delay.

GD32470i-EVAL-V1.0 board has three LEDs. The LED1, LED2 and LED3 are controlled by GPIO. This demo will show how to light the LEDs.

#### 5.1.2. DEMO running result

Download the program <01\_GPIO\_Running\_LED> to the EVAL board, LED1, LED2 and LED3 will turn on in sequence with interval of 1000ms, and repeat the process.

### 5.2. GPIO\_Key\_Polling\_mode

#### 5.2.1. DEMO purpose

This demo includes the following functions of GD32 MCU:

- Learn to use GPIO control the LED and the Key.
- Learn to use SysTick to generate 1ms delay.

GD32470i-EVAL-V1.0 board has four keys and three LEDs. The four keys are Reset key, Tamper key, Wakeup key and User key. The LED1, LED2 and LED3 are controlled by GPIO.

This demo will show how to use the Tamper key to control the LED2. When press down the Tamper Key, it will check the input value of the IO port. If the value is 0 and will wait for 100ms. Check the input value of the IO port again. If the value still is 0, it indicates that the button is pressed successfully and toggle LED2.

#### 5.2.2. DEMO running result

Download the program <02\_GPIO\_Key\_Polling\_mode> to the EVAL board, Press down the Tamper Key, LED2 will be turned on. Press down the Tamper Key again, LED2 will be turned off.

## 5.3. EXTI\_Key\_Interrupt\_mode

### 5.3.1. DEMO purpose

This demo includes the following functions of GD32 MCU:

- Learn to use GPIO control the LED and the KEY.
- Learn to use EXTI to generate external interrupt.

GD32470i-EVAL-V1.0 board has four keys and three LEDs. The four keys are Reset key, Tamper key, Wakeup key and User key. The LED1, LED2 and LED3 are controlled by GPIO.

This demo will show how to use the EXTI interrupt line to control the LED2. When press down the Tamper Key, it will produce an interrupt. In the interrupt service function, the demo will toggle LED2.

### 5.3.2. DEMO running result

Download the program <03\_EXTI\_Key\_Interrupt\_mode> to the EVAL board, LED2 is turned on and off for test. Press down the Tamper Key, LED2 will be turned on. Press down the Tamper Key again, LED2 will be turned off.

## 5.4. USART\_Printf

### 5.4.1. DEMO purpose

This demo includes the following functions of GD32 MCU:

- Learn to use GPIO control the LED
- Learn to retarget the C library printf function to the USART

### 5.4.2. DEMO running result

Download the program < 04\_USART\_Printf > to the EVAL board, connect serial cable to COM0 and jump JP5 to USART. This implementation outputs “USART printf example: please press the Tamper key” on the HyperTerminal using COM0. Press the Tamper key, the LED3 will be turned on and serial port will output “USART printf example”.

The output information via the serial port is as following.

```
USART printf example: please press the Tamper key
USART printf example
```

## 5.5. USART\_Echo\_Interrupt\_mode

### 5.5.1. DEMO purpose

This demo includes the following functions of GD32 MCU:

- Learn to use the USART transmit and receive interrupts to communicate with the serial terminal tool.

### 5.5.2. DEMO running result

Download the program < 05\_USART\_Echo\_Interrupt\_mode > to the EVAL board, connect serial cable to COM0 and jump JP5 to USART. Firstly, all the LEDs are turned on and off for test. Then, the COM0 sends the tx\_buffer array (from 0x00 to 0xFF) to the serial terminal tool supporting hex format communication and waits for receiving data of BUFFER\_SIZE bytes from the serial terminal. The data MCU has received is stored in the rx\_buffer array. After that, compare tx\_buffer with rx\_buffer. If tx\_buffer is same with rx\_buffer, LED1, LED2, LED3 flash by turns. Otherwise, LED1, LED2, LED3 toggle together.

The output information via the serial port is as following.

```
00 01 02 03 04 05 06 07 08 09 0A 0B 0C 0D 0E 0F 10 11 12 13 14 15 16 17 18 19 1A 1B
1C 1D 1E 1F 20 21 22 23 24 25 26 27 28 29 2A 2B 2C 2D 2E 2F 30 31 32 33 34 35 36 37
38 39 3A 3B 3C 3D 3E 3F 40 41 42 43 44 45 46 47 48 49 4A 4B 4C 4D 4E 4F 50 51 52 53
54 55 56 57 58 59 5A 5B 5C 5D 5E 5F 60 61 62 63 64 65 66 67 68 69 6A 6B 6C 6D 6E 6F
70 71 72 73 74 75 76 77 78 79 7A 7B 7C 7D 7E 7F 80 81 82 83 84 85 86 87 88 89 8A 8B
8C 8D 8E 8F 90 91 92 93 94 95 96 97 98 99 9A 9B 9C 9D 9E 9F A0 A1 A2 A3 A4 A5 A6 A7
A8 A9 AA AB AC AD AE AF B0 B1 B2 B3 B4 B5 B6 B7 B8 B9 BA BB BC BD BE BF C0 C1 C2 C3
C4 C5 C6 C7 C8 C9 CA CB CC CD CE CF D0 D1 D2 D3 D4 D5 D6 D7 D8 D9 DA DB DC DD DE DF
E0 E1 E2 E3 E4 E5 E6 E7 E8 E9 EA EB EC ED EE EF F0 F1 F2 F3 F4 F5 F6 F7 F8 F9 FA FB
FC FD FE FF
```

## 5.6. USART\_DMA

### 5.6.1. DEMO purpose

This demo includes the following functions of GD32 MCU:

- Learn to use the USART transmit and receive data using DMA.

### 5.6.2. DEMO running result

Download the program < 06\_USART\_DMA > to the EVAL board, connect serial cable to COM0 and jump JP5 to USART. Firstly, all the LEDs are turned on and off for test. Then, the COM0 sends the tx\_buffer array (from 0x00 to 0xFF) to the serial terminal tool supporting hex format communication and waits for receiving data of same bytes as tx\_buffer from the serial terminal. The data MCU have received is stored in the rx\_buffer array. After that, compare tx\_buffer with rx\_buffer. If tx\_buffer is same with rx\_buffer,



LED1, LED2, LED3 flash by turns. Otherwise, LED1, LED2, LED3 toggle together.

```
00 01 02 03 04 05 06 07 08 09 0A 0B 0C 0D 0E 0F 10 11 12 13 14 15 16 17 18 19 1A 1B
1C 1D 1E 1F 20 21 22 23 24 25 26 27 28 29 2A 2B 2C 2D 2E 2F 30 31 32 33 34 35 36 37
38 39 3A 3B 3C 3D 3E 3F 40 41 42 43 44 45 46 47 48 49 4A 4B 4C 4D 4E 4F 50 51 52 53
54 55 56 57 58 59 5A 5B 5C 5D 5E 5F 60 61 62 63 64 65 66 67 68 69 6A 6B 6C 6D 6E 6F
70 71 72 73 74 75 76 77 78 79 7A 7B 7C 7D 7E 7F 80 81 82 83 84 85 86 87 88 89 8A 8B
8C 8D 8E 8F 90 91 92 93 94 95 96 97 98 99 9A 9B 9C 9D 9E 9F A0 A1 A2 A3 A4 A5 A6 A7
A8 A9 AA AB AC AD AE AF B0 B1 B2 B3 B4 B5 B6 B7 B8 B9 BA BB BC BD BE BF C0 C1 C2 C3
C4 C5 C6 C7 C8 C9 CA CB CC CD CE CF D0 D1 D2 D3 D4 D5 D6 D7 D8 D9 DA DB DC DD DE DF
EO E1 E2 E3 E4 E5 E6 E7 E8 E9 EA EB EC ED EE EF FO F1 F2 F3 F4 F5 F6 F7 F8 F9 FA FB
FC FD FE FF |
```

## 5.7. ADC\_Temperature\_Vrefint

### 5.7.1. DEMO purpose

This demo includes the following functions of GD32 MCU:

- Learn to use the ADC to convert analog signal to digital data
- Learn to get the value of inner channel 16(temperature sensor channel), channel 17 (VREFINT channel) and channel 18(VBAT/4 channel)

### 5.7.2. DEMO running result

Jump the JP5 to USART with the jumper cap, and then download the program <07\_ADC\_Temperature\_Vrefint\_Vbat> to the board. Connect serial cable to COM0, open the HyperTerminal.

When the program is running, HyperTerminal display the value of temperature, internal voltage reference (VREFINT) and external battery voltage VBAT.

Notice: because there is an offset, when inner temperature sensor is used to detect accurate temperature, an external temperature sensor part should be used to calibrate the offset error.

```
the temperature data is 24 degrees Celsius
the reference voltage data is 1.198V
the battery voltage is 3.213V

the temperature data is 25 degrees Celsius
the reference voltage data is 1.201V
the battery voltage is 3.213V

the temperature data is 25 degrees Celsius
the reference voltage data is 1.199V
the battery voltage is 3.203V

the temperature data is 25 degrees Celsius
the reference voltage data is 1.198V
the battery voltage is 3.213V
```

## 5.8. ADC0\_ADC1\_Follow\_up\_mode

### 5.8.1. DEMO purpose

This demo includes the following functions of GD32 MCU:

- Learn to use the ADC to convert analog signal to digital data
- Learn to use ADC0 and ADC1 follow-up mode

### 5.8.2. DEMO running result

Jump the JP5 to USART with the jumper cap, and then download the program <08\_ADC0\_ADC1\_Follow\_up\_mode> to the board. Connect serial cable to COM0, open the HyperTerminal. PC5 pin connect to the external voltage input. PC3 is the output voltage of the slide rheostat VR1 on board. Keep PC5 pin should not be reused by other peripherals. JP17 should not be connected.

TIMER1\_CH1 is the trigger source of ADC0 and ADC1. When the rising edge of TIMER1\_CH1 coming, ADC0 starts immediately and ADC1 starts after a delay of several ADC clock cycles. The values of ADC0 and ADC1 are transmitted to array `adc_value[0]` and `adc_value [1]` by DMA.

When sampling the first channel of ADCx (x=0,1), the value of the ADC0 conversion of PC3 pin is stored into the low half word of `adc_value [0]`, and after a delay of several ADC clock cycles the value of the ADC1 conversion of PC5 pin is stored into the high half word of `adc_value [0]`. When sampling the second channel of ADCx (x=0,1), the value of the ADC0 conversion of PC5 pin is stored into the low half word of `adc_value [1]`, and after a delay of several ADC clock cycles the value of the ADC1 conversion of PC3 pin is stored into the high half word of `adc_value [1]`.

When the program is running, HyperTerminal display the regular value of ADC0 and ADC1 by `adc_value [0]` and `adc_value [1]`.

```
the data adc_value[0] is 00DE0FF3
the data adc_value[1] is 0FFF00A3

the data adc_value[0] is 00E30FFE
the data adc_value[1] is 0FFF00A4

the data adc_value[0] is 00EA0FF9
the data adc_value[1] is 0FF400B2

the data adc_value[0] is 00DE0FFF
the data adc_value[1] is 0FFE00A9

the data adc_value[0] is 00E00FF1
the data adc_value[1] is 0FF500A6
```

## 5.9. ADC0\_ADC1\_Regular\_Parallel\_mode

### 5.9.1. DEMO purpose

This demo includes the following functions of GD32 MCU:

- Learn to use the ADC to convert analog signal to digital data
- Learn to use ADC0 and ADC1 regular parallel mode

### 5.9.2. DEMO running result

Jump the JP5 to USART with the jumper cap, and then download the program <09\_ADC0\_ADC1\_Regular\_Parallel\_mode> to the board. Connect serial cable to COM0, open the HyperTerminal. PC5 pin connect to the external voltage input. PC3 is the output voltage of the slide rheostat VR1 on board. Keep PC5 pin should not be reused by other peripherals. JP17 should not be connected.

TIMER1\_CH1 is the trigger source of ADC0 and ADC1. When the rising edge of TIMER1\_CH1 coming, ADC0 and ADC1 convert the regular channel group parallelly. The values of ADC0 and ADC1 are transmitted to array `adc_value[0]` and `adc_value [1]` by DMA.

When sampling the first channel of ADCx (x=0,1), the value of the ADC0 conversion of PC3 pin is stored into the low half word of `adc_value [0]`, the value of the ADC1 conversion of PC5 pin is stored into the high half word of `adc_value [0]`. When sampling the second channel of ADCx (x=0,1), the value of the ADC0 conversion of PC5 pin is stored into the low half word of `adc_value [1]`, the value of the ADC1 conversion of PC3 pin is stored into the high half word of `adc_value [1]`.

When the program is running, HyperTerminal displays the regular value of ADC0 and ADC1 stored in `adc_value [0]` and `adc_value [1]`.

```
the data adc_value[0] is 06210000
the data adc_value[1] is 00000627

the data adc_value[0] is 06290B29
the data adc_value[1] is 0B40061F

the data adc_value[0] is 06250B49
the data adc_value[1] is 0B590629

the data adc_value[0] is 06280B3F
the data adc_value[1] is 0B320628

the data adc_value[0] is 06230B30
the data adc_value[1] is 0B430622
```

## 5.10. DAC\_Output\_Voltage\_Value

### 5.10.1. DEMO purpose

This demo includes the following functions of GD32 MCU:

- Learn to use DAC to output voltage on DAC0 output

### 5.10.2. DEMO running result

Download the program <10\_DAC\_Output\_Voltage\_Value> to the EVAL board and run, all the LEDs will turn on and turn off for test. The digital value is 0x7FF0, its converted analog voltage should be 1.65V ( $V_{REF}/2$ ), using the voltmeter to measure PA4 or DAC\_OUT0 on JP7, its value is 1.65V. And the signal can be observed through the oscilloscope.

## 5.11. I2C\_EEPROM

### 5.11.1. DEMO purpose

This demo includes the following functions of GD32 MCU:

- Learn to use the master transmitting mode of I2C module;
- Learn to use the master receiving mode of I2C module;
- Learn to read and write the EEPROM with I2C interface.

### 5.11.2. DEMO running result

Download the program <11\_I2C\_EEPROM> to the EVAL board and run. Connect serial cable to COM0, jump JP5 to USART, then open the HyperTerminal to show the print message.

Firstly, the data of 256 bytes will be written to the EEPROM from the address 0x00 and printed by the serial port. Then, reading the EEPROM from address 0x00 for 256 bytes and the result will be printed. Finally, compare the data that were written to the EEPROM and the data that were read from the EEPROM. If they are the same, the serial port will output “I2C-AT24C02 test passed!” and the four LEDs lights flashing, otherwise the serial port will output “Err: data read and write aren’t matching.” And all the four LEDs light.

The output information via the serial port is as following.

```
GD32470I-EVAL I2C-24C02 configured...
The I2C0 is hardware interface
The speed is 400000
AT24C02 writing...
0x00 0x01 0x02 0x03 0x04 0x05 0x06 0x07 0x08 0x09 0x0A 0x0B 0x0C 0x0D 0x0E 0x0F
0x10 0x11 0x12 0x13 0x14 0x15 0x16 0x17 0x18 0x19 0x1A 0x1B 0x1C 0x1D 0x1E 0x1F
0x20 0x21 0x22 0x23 0x24 0x25 0x26 0x27 0x28 0x29 0x2A 0x2B 0x2C 0x2D 0x2E 0x2F
0x30 0x31 0x32 0x33 0x34 0x35 0x36 0x37 0x38 0x39 0x3A 0x3B 0x3C 0x3D 0x3E 0x3F
0x40 0x41 0x42 0x43 0x44 0x45 0x46 0x47 0x48 0x49 0x4A 0x4B 0x4C 0x4D 0x4E 0x4F
0x50 0x51 0x52 0x53 0x54 0x55 0x56 0x57 0x58 0x59 0x5A 0x5B 0x5C 0x5D 0x5E 0x5F
0x60 0x61 0x62 0x63 0x64 0x65 0x66 0x67 0x68 0x69 0x6A 0x6B 0x6C 0x6D 0x6E 0x6F
0x70 0x71 0x72 0x73 0x74 0x75 0x76 0x77 0x78 0x79 0x7A 0x7B 0x7C 0x7D 0x7E 0x7F
0x80 0x81 0x82 0x83 0x84 0x85 0x86 0x87 0x88 0x89 0x8A 0x8B 0x8C 0x8D 0x8E 0x8F
0x90 0x91 0x92 0x93 0x94 0x95 0x96 0x97 0x98 0x99 0x9A 0x9B 0x9C 0x9D 0x9E 0x9F
0xA0 0xA1 0xA2 0xA3 0xA4 0xA5 0xA6 0xA7 0xA8 0xA9 0xAA 0xAB 0xAC 0xAD 0xAE 0xAF
0xB0 0xB1 0xB2 0xB3 0xB4 0xB5 0xB6 0xB7 0xB8 0xB9 0xBA 0xBB 0xBC 0xBD 0xBE 0xBF
0xC0 0xC1 0xC2 0xC3 0xC4 0xC5 0xC6 0xC7 0xC8 0xC9 0xCA 0xCB 0xCC 0xCD 0xCE 0xCF
0xD0 0xD1 0xD2 0xD3 0xD4 0xD5 0xD6 0xD7 0xD8 0xD9 0xDA 0xDB 0xDC 0xDD 0xDE 0xDF
0xE0 0xE1 0xE2 0xE3 0xE4 0xE5 0xE6 0xE7 0xE8 0xE9 0xEA 0xEB 0xEC 0xED 0xEE 0xEF
0xF0 0xF1 0xF2 0xF3 0xF4 0xF5 0xF6 0xF7 0xF8 0xF9 0xFA 0xFB 0xFC 0xFD 0xFE 0xFF
AT24C02 reading...
0x00 0x01 0x02 0x03 0x04 0x05 0x06 0x07 0x08 0x09 0x0A 0x0B 0x0C 0x0D 0x0E 0x0F
0x10 0x11 0x12 0x13 0x14 0x15 0x16 0x17 0x18 0x19 0x1A 0x1B 0x1C 0x1D 0x1E 0x1F
0x20 0x21 0x22 0x23 0x24 0x25 0x26 0x27 0x28 0x29 0x2A 0x2B 0x2C 0x2D 0x2E 0x2F
0x30 0x31 0x32 0x33 0x34 0x35 0x36 0x37 0x38 0x39 0x3A 0x3B 0x3C 0x3D 0x3E 0x3F
0x40 0x41 0x42 0x43 0x44 0x45 0x46 0x47 0x48 0x49 0x4A 0x4B 0x4C 0x4D 0x4E 0x4F
0x50 0x51 0x52 0x53 0x54 0x55 0x56 0x57 0x58 0x59 0x5A 0x5B 0x5C 0x5D 0x5E 0x5F
0x60 0x61 0x62 0x63 0x64 0x65 0x66 0x67 0x68 0x69 0x6A 0x6B 0x6C 0x6D 0x6E 0x6F
0x70 0x71 0x72 0x73 0x74 0x75 0x76 0x77 0x78 0x79 0x7A 0x7B 0x7C 0x7D 0x7E 0x7F
0x80 0x81 0x82 0x83 0x84 0x85 0x86 0x87 0x88 0x89 0x8A 0x8B 0x8C 0x8D 0x8E 0x8F
0x90 0x91 0x92 0x93 0x94 0x95 0x96 0x97 0x98 0x99 0x9A 0x9B 0x9C 0x9D 0x9E 0x9F
0xA0 0xA1 0xA2 0xA3 0xA4 0xA5 0xA6 0xA7 0xA8 0xA9 0xAA 0xAB 0xAC 0xAD 0xAE 0xAF
0xB0 0xB1 0xB2 0xB3 0xB4 0xB5 0xB6 0xB7 0xB8 0xB9 0xBA 0xBB 0xBC 0xBD 0xBE 0xBF
0xC0 0xC1 0xC2 0xC3 0xC4 0xC5 0xC6 0xC7 0xC8 0xC9 0xCA 0xCB 0xCC 0xCD 0xCE 0xCF
0xD0 0xD1 0xD2 0xD3 0xD4 0xD5 0xD6 0xD7 0xD8 0xD9 0xDA 0xDB 0xDC 0xDD 0xDE 0xDF
0xE0 0xE1 0xE2 0xE3 0xE4 0xE5 0xE6 0xE7 0xE8 0xE9 0xEA 0xEB 0xEC 0xED 0xEE 0xEF
0xF0 0xF1 0xF2 0xF3 0xF4 0xF5 0xF6 0xF7 0xF8 0xF9 0xFA 0xFB 0xFC 0xFD 0xFE 0xFF
I2C-AT24C02 test passed!
```

## 5.12. SPI\_QSPI\_Flash

### 5.12.1. DEMO purpose

This demo includes the following functions of GD32 MCU:

- Learn to use the Quad-SPI mode of SPI unit to read and write NOR Flash with the SPI

---

interface

GD32470I-EVAL-V1.0 board integrates SPI5 module with Quad-SPI mode and the mode can communicate with external NOR Flash devices. The SPI NOR FLASH is a serial FLASH memory chip GD25Q16B which size is 16Mbit, the chip supports standard SPI and quad SPI operation instructions.

### 5.12.2. DEMO running result

The computer serial port line connected to the COM0 port of development board, set the baud rate of HyperTerminal software to 115200, 8 bits data bit, 1 bit stop bit. At the same time you should jump the JP5 to USART, and jump the JP12, JP13, JP20 to SPI.

Download the program <12\_SPI\_QSPI\_Flash> to the EVAL board, the HyperTerminal software can observe the operation condition and will display the ID of the flash, 256 bytes data which are written to and read from flash. Compare the data that were written to the flash and the data that were read from the flash. If they are the same, the serial port will output "SPI-GD25Q16 Test Passed!", otherwise, the serial port will output "Err: Data Read and Write aren't Matching.". At last, turn on and off the leds one by one. The following is the experimental results.

```
#####
GD32F470I-EVAL System is Starting up...
GD32F470I-EVAL The CPU Unique Device ID: [33394150-4323830-34317A1B]
GD32F470I-EVAL SPI Flash:GD25Q16 configured...
The Flash_ID:0xC84015
Write to tx_buffer:
0x00 0x01 0x02 0x03 0x04 0x05 0x06 0x07 0x08 0x09 0x0A 0x0B 0x0C 0x0D 0x0E 0x0F
0x10 0x11 0x12 0x13 0x14 0x15 0x16 0x17 0x18 0x19 0x1A 0x1B 0x1C 0x1D 0x1E 0x1F
0x20 0x21 0x22 0x23 0x24 0x25 0x26 0x27 0x28 0x29 0x2A 0x2B 0x2C 0x2D 0x2E 0x2F
0x30 0x31 0x32 0x33 0x34 0x35 0x36 0x37 0x38 0x39 0x3A 0x3B 0x3C 0x3D 0x3E 0x3F
0x40 0x41 0x42 0x43 0x44 0x45 0x46 0x47 0x48 0x49 0x4A 0x4B 0x4C 0x4D 0x4E 0x4F
0x50 0x51 0x52 0x53 0x54 0x55 0x56 0x57 0x58 0x59 0x5A 0x5B 0x5C 0x5D 0x5E 0x5F
0x60 0x61 0x62 0x63 0x64 0x65 0x66 0x67 0x68 0x69 0x6A 0x6B 0x6C 0x6D 0x6E 0x6F
0x70 0x71 0x72 0x73 0x74 0x75 0x76 0x77 0x78 0x79 0x7A 0x7B 0x7C 0x7D 0x7E 0x7F
0x80 0x81 0x82 0x83 0x84 0x85 0x86 0x87 0x88 0x89 0x8A 0x8B 0x8C 0x8D 0x8E 0x8F
0x90 0x91 0x92 0x93 0x94 0x95 0x96 0x97 0x98 0x99 0x9A 0x9B 0x9C 0x9D 0x9E 0x9F
0xA0 0xA1 0xA2 0xA3 0xA4 0xA5 0xA6 0xA7 0xA8 0xA9 0xAA 0xAB 0xAC 0xAD 0xAE 0xAF
0xB0 0xB1 0xB2 0xB3 0xB4 0xB5 0xB6 0xB7 0xB8 0xB9 0xBA 0xBB 0xBC 0xBD 0xBE 0xBF
0xC0 0xC1 0xC2 0xC3 0xC4 0xC5 0xC6 0xC7 0xC8 0xC9 0xCA 0xCB 0xCC 0xCD 0xCE 0xCF
0xD0 0xD1 0xD2 0xD3 0xD4 0xD5 0xD6 0xD7 0xD8 0xD9 0xDA 0xDB 0xDC 0xDD 0xDE 0xDF
0xE0 0xE1 0xE2 0xE3 0xE4 0xE5 0xE6 0xE7 0xE8 0xE9 0xEA 0xEB 0xEC 0xED 0xEE 0xEF
0xF0 0xF1 0xF2 0xF3 0xF4 0xF5 0xF6 0xF7 0xF8 0xF9 0xFA 0xFB 0xFC 0xFD 0xFE 0xFF

Read from rx_buffer:
0x00 0x01 0x02 0x03 0x04 0x05 0x06 0x07 0x08 0x09 0x0A 0x0B 0x0C 0x0D 0x0E 0x0F
0x10 0x11 0x12 0x13 0x14 0x15 0x16 0x17 0x18 0x19 0x1A 0x1B 0x1C 0x1D 0x1E 0x1F
0x20 0x21 0x22 0x23 0x24 0x25 0x26 0x27 0x28 0x29 0x2A 0x2B 0x2C 0x2D 0x2E 0x2F
0x30 0x31 0x32 0x33 0x34 0x35 0x36 0x37 0x38 0x39 0x3A 0x3B 0x3C 0x3D 0x3E 0x3F
0x40 0x41 0x42 0x43 0x44 0x45 0x46 0x47 0x48 0x49 0x4A 0x4B 0x4C 0x4D 0x4E 0x4F
0x50 0x51 0x52 0x53 0x54 0x55 0x56 0x57 0x58 0x59 0x5A 0x5B 0x5C 0x5D 0x5E 0x5F
0x60 0x61 0x62 0x63 0x64 0x65 0x66 0x67 0x68 0x69 0x6A 0x6B 0x6C 0x6D 0x6E 0x6F
0x70 0x71 0x72 0x73 0x74 0x75 0x76 0x77 0x78 0x79 0x7A 0x7B 0x7C 0x7D 0x7E 0x7F
0x80 0x81 0x82 0x83 0x84 0x85 0x86 0x87 0x88 0x89 0x8A 0x8B 0x8C 0x8D 0x8E 0x8F
0x90 0x91 0x92 0x93 0x94 0x95 0x96 0x97 0x98 0x99 0x9A 0x9B 0x9C 0x9D 0x9E 0x9F
0xA0 0xA1 0xA2 0xA3 0xA4 0xA5 0xA6 0xA7 0xA8 0xA9 0xAA 0xAB 0xAC 0xAD 0xAE 0xAF
0xB0 0xB1 0xB2 0xB3 0xB4 0xB5 0xB6 0xB7 0xB8 0xB9 0xBA 0xBB 0xBC 0xBD 0xBE 0xBF
0xC0 0xC1 0xC2 0xC3 0xC4 0xC5 0xC6 0xC7 0xC8 0xC9 0xCA 0xCB 0xCC 0xCD 0xCE 0xCF
0xD0 0xD1 0xD2 0xD3 0xD4 0xD5 0xD6 0xD7 0xD8 0xD9 0xDA 0xDB 0xDC 0xDD 0xDE 0xDF
0xE0 0xE1 0xE2 0xE3 0xE4 0xE5 0xE6 0xE7 0xE8 0xE9 0xEA 0xEB 0xEC 0xED 0xEE 0xEF
0xF0 0xF1 0xF2 0xF3 0xF4 0xF5 0xF6 0xF7 0xF8 0xF9 0xFA 0xFB 0xFC 0xFD 0xFE 0xFF
SPI-GD25Q16 Test Passed!
```

## 5.13. I2S\_Audio\_Player

### 5.13.1. DEMO purpose

This Demo includes the following functions of GD32 MCU:

- Learn to use I2S module to output audio file
- Parsing audio files of wav format

GD32470I-EVAL-V1.0 board integrates the I2S(Inter-IC Sound) module, and the module can communicate with external devices using the I2S audio protocol. This Demo mainly shows

how to use the I2S interface of the board for audio output.

### 5.13.2. DEMO running result

Download the program<13\_I2S\_Audio\_Player>to the EVAL board, jump the JP18 to I2S with the jumper cap, insert the headphone into the audio port, and then listen to the audio file.

## 5.14. EXMC\_SDRAM

### 5.14.1. DEMO purpose

This demo includes the following function of GD32 MCU:

- Learn to use EXMC control the SDRAM.

### 5.14.2. DEMO running result

GD32470I-EVAL board has EXMC module to control SDRAM. Before running the demo, JP17 must be fitted to SDRAM, JP5 must be fitted to USART. Download the program <14\_EXMC\_SDRAM> to the EVAL board. This demo shows the write and read operation process of SDRAM memory by EXMC module. If the test succeed, LED1 will be turned on. Otherwise, turn on the LED3. Information via a HyperTerminal output as following:



```

SDRAM initialized!
SDRAM write data completed!
SDRAM read data completed!
Check the data!
SDRAM test succeeded!
The data is:
 0  1  2  3  4  5  6  7  8  9  a  b  c  d  e  f
10 11 12 13 14 15 16 17 18 19 1a 1b 1c 1d 1e 1f
20 21 22 23 24 25 26 27 28 29 2a 2b 2c 2d 2e 2f
30 31 32 33 34 35 36 37 38 39 3a 3b 3c 3d 3e 3f
40 41 42 43 44 45 46 47 48 49 4a 4b 4c 4d 4e 4f
50 51 52 53 54 55 56 57 58 59 5a 5b 5c 5d 5e 5f
60 61 62 63 64 65 66 67 68 69 6a 6b 6c 6d 6e 6f
70 71 72 73 74 75 76 77 78 79 7a 7b 7c 7d 7e 7f
80 81 82 83 84 85 86 87 88 89 8a 8b 8c 8d 8e 8f
90 91 92 93 94 95 96 97 98 99 9a 9b 9c 9d 9e 9f
a0 a1 a2 a3 a4 a5 a6 a7 a8 a9 aa ab ac ad ae af
b0 b1 b2 b3 b4 b5 b6 b7 b8 b9 ba bb bc bd be bf
c0 c1 c2 c3 c4 c5 c6 c7 c8 c9 ca cb cc cd ce cf
d0 d1 d2 d3 d4 d5 d6 d7 d8 d9 da db dc dd de df
e0 e1 e2 e3 e4 e5 e6 e7 e8 e9 ea eb ec ed ee ef
f0 f1 f2 f3 f4 f5 f6 f7 f8 f9 fa fb fc fd fe ff

 0  1  2  3  4  5  6  7  8  9  a  b  c  d  e  f
10 11 12 13 14 15 16 17 18 19 1a 1b 1c 1d 1e 1f
20 21 22 23 24 25 26 27 28 29 2a 2b 2c 2d 2e 2f
30 31 32 33 34 35 36 37 38 39 3a 3b 3c 3d 3e 3f
40 41 42 43 44 45 46 47 48 49 4a 4b 4c 4d 4e 4f
50 51 52 53 54 55 56 57 58 59 5a 5b 5c 5d 5e 5f
60 61 62 63 64 65 66 67 68 69 6a 6b 6c 6d 6e 6f
70 71 72 73 74 75 76 77 78 79 7a 7b 7c 7d 7e 7f
80 81 82 83 84 85 86 87 88 89 8a 8b 8c 8d 8e 8f
90 91 92 93 94 95 96 97 98 99 9a 9b 9c 9d 9e 9f
a0 a1 a2 a3 a4 a5 a6 a7 a8 a9 aa ab ac ad ae af
b0 b1 b2 b3 b4 b5 b6 b7 b8 b9 ba bb bc bd be bf
c0 c1 c2 c3 c4 c5 c6 c7 c8 c9 ca cb cc cd ce cf
d0 d1 d2 d3 d4 d5 d6 d7 d8 d9 da db dc dd de df
e0 e1 e2 e3 e4 e5 e6 e7 e8 e9 ea eb ec ed ee ef
f0 f1 f2 f3 f4 f5 f6 f7 f8 f9 fa fb fc fd fe ff

 0  1  2  3  4  5  6  7  8  9  a  b  c  d  e  f
10 11 12 13 14 15 16 17 18 19 1a 1b 1c 1d 1e 1f
20 21 22 23 24 25 26 27 28 29 2a 2b 2c 2d 2e 2f
30 31 32 33 34 35 36 37 38 39 3a 3b 3c 3d 3e 3f
40 41 42 43 44 45 46 47 48 49 4a 4b 4c 4d 4e 4f
50 51 52 53 54 55 56 57 58 59 5a 5b 5c 5d 5e 5f
60 61 62 63 64 65 66 67 68 69 6a 6b 6c 6d 6e 6f
70 71 72 73 74 75 76 77 78 79 7a 7b 7c 7d 7e 7f
80 81 82 83 84 85 86 87 88 89 8a 8b 8c 8d 8e 8f
90 91 92 93 94 95 96 97 98 99 9a 9b 9c 9d 9e 9f
a0 a1 a2 a3 a4 a5 a6 a7 a8 a9 aa ab ac ad ae af
b0 b1 b2 b3 b4 b5 b6 b7 b8 b9 ba bb bc bd be bf
c0 c1 c2 c3 c4 c5 c6 c7 c8 c9 ca cb cc cd ce cf
d0 d1 d2 d3 d4 d5 d6 d7 d8 d9 da db dc dd de df
e0 e1 e2 e3 e4 e5 e6 e7 e8 e9 ea eb ec ed ee ef
f0 f1 f2 f3 f4 f5 f6 f7 f8 f9 fa fb fc fd fe ff

```

## 5.15. EXMC\_SDRAM\_DeepSleep

### 5.15.1. DEMO purpose

This demo includes the following functions of GD32 MCU:

- Learn to use EXMC control the SDRAM;

- Learn to use deepsleep mode.

### 5.15.2. DEMO running result

GD32470I-EVAL board has EXMC module to control SDRAM. Before running the demo, JP17 must be fitted to SDRAM, JP5 must be fitted to USART. Download the program <15\_EXMC\_SDRAM\_DeepSleep> to the EVAL board. This demo shows how to use SDRAM in the deepsleep mode. Firstly, MCU works in the normal mode, SDRAM auto-refresh cycles are performed by MCU, we write the specified data to the SDRAM. Secondly, we make the MCU to deepsleep mode, at the time, SDRAM auto-refresh cycles are performed by itself and LED2 will light on. Thirdly, press the user key to wake up MCU, compare the data which read from SDRAM with the write data, if the test pass, LED1 will be turned on. Otherwise, turn on the LED3. Information via a HyperTerminal output as following:

```

SDRAM initialized!
SDRAM write data completed!
Enter deepsleep mode!
Press the user key to wakeup the MCU!

User key has been pressed!
SDRAM read data completed!
Check the data!
SDRAM test succeeded!
The data is:
  0   1   2   3   4   5   6   7   8   9   a   b   c   d   e   f
10  11  12  13  14  15  16  17  18  19  1a  1b  1c  1d  1e  1f
20  21  22  23  24  25  26  27  28  29  2a  2b  2c  2d  2e  2f
30  31  32  33  34  35  36  37  38  39  3a  3b  3c  3d  3e  3f
40  41  42  43  44  45  46  47  48  49  4a  4b  4c  4d  4e  4f
50  51  52  53  54  55  56  57  58  59  5a  5b  5c  5d  5e  5f
60  61  62  63  64  65  66  67  68  69  6a  6b  6c  6d  6e  6f
70  71  72  73  74  75  76  77  78  79  7a  7b  7c  7d  7e  7f
80  81  82  83  84  85  86  87  88  89  8a  8b  8c  8d  8e  8f
90  91  92  93  94  95  96  97  98  99  9a  9b  9c  9d  9e  9f
a0  a1  a2  a3  a4  a5  a6  a7  a8  a9  aa  ab  ac  ad  ae  af
b0  b1  b2  b3  b4  b5  b6  b7  b8  b9  ba  bb  bc  bd  be  bf
c0  c1  c2  c3  c4  c5  c6  c7  c8  c9  ca  cb  cc  cd  ce  cf
d0  d1  d2  d3  d4  d5  d6  d7  d8  d9  da  db  dc  dd  de  df
e0  e1  e2  e3  e4  e5  e6  e7  e8  e9  ea  eb  ec  ed  ee  ef
f0  f1  f2  f3  f4  f5  f6  f7  f8  f9  fa  fb  fc  fd  fe  ff

  0   1   2   3   4   5   6   7   8   9   a   b   c   d   e   f
10  11  12  13  14  15  16  17  18  19  1a  1b  1c  1d  1e  1f
20  21  22  23  24  25  26  27  28  29  2a  2b  2c  2d  2e  2f
30  31  32  33  34  35  36  37  38  39  3a  3b  3c  3d  3e  3f
40  41  42  43  44  45  46  47  48  49  4a  4b  4c  4d  4e  4f
50  51  52  53  54  55  56  57  58  59  5a  5b  5c  5d  5e  5f
60  61  62  63  64  65  66  67  68  69  6a  6b  6c  6d  6e  6f
70  71  72  73  74  75  76  77  78  79  7a  7b  7c  7d  7e  7f
80  81  82  83  84  85  86  87  88  89  8a  8b  8c  8d  8e  8f
90  91  92  93  94  95  96  97  98  99  9a  9b  9c  9d  9e  9f
a0  a1  a2  a3  a4  a5  a6  a7  a8  a9  aa  ab  ac  ad  ae  af
b0  b1  b2  b3  b4  b5  b6  b7  b8  b9  ba  bb  bc  bd  be  bf
c0  c1  c2  c3  c4  c5  c6  c7  c8  c9  ca  cb  cc  cd  ce  cf
d0  d1  d2  d3  d4  d5  d6  d7  d8  d9  da  db  dc  dd  de  df
e0  e1  e2  e3  e4  e5  e6  e7  e8  e9  ea  eb  ec  ed  ee  ef
f0  f1  f2  f3  f4  f5  f6  f7  f8  f9  fa  fb  fc  fd  fe  ff

  0   1   2   3   4   5   6   7   8   9   a   b   c   d   e   f
10  11  12  13  14  15  16  17  18  19  1a  1b  1c  1d  1e  1f
20  21  22  23  24  25  26  27  28  29  2a  2b  2c  2d  2e  2f
30  31  32  33  34  35  36  37  38  39  3a  3b  3c  3d  3e  3f
40  41  42  43  44  45  46  47  48  49  4a  4b  4c  4d  4e  4f
50  51  52  53  54  55  56  57  58  59  5a  5b  5c  5d  5e  5f
60  61  62  63  64  65  66  67  68  69  6a  6b  6c  6d  6e  6f
70  71  72  73  74  75  76  77  78  79  7a  7b  7c  7d  7e  7f
80  81  82  83  84  85  86  87  88  89  8a  8b  8c  8d  8e  8f
90  91  92  93  94  95  96  97  98  99  9a  9b  9c  9d  9e  9f
a0  a1  a2  a3  a4  a5  a6  a7  a8  a9  aa  ab  ac  ad  ae  af
b0  b1  b2  b3  b4  b5  b6  b7  b8  b9  ba  bb  bc  bd  be  bf
c0  c1  c2  c3  c4  c5  c6  c7  c8  c9  ca  cb  cc  cd  ce  cf
d0  d1  d2  d3  d4  d5  d6  d7  d8  d9  da  db  dc  dd  de  df
e0  e1  e2  e3  e4  e5  e6  e7  e8  e9  ea  eb  ec  ed  ee  ef
f0  f1  f2  f3  f4  f5  f6  f7  f8  f9  fa  fb  fc  fd  fe  ff

```

## 5.16. EXMC\_NandFlash

### 5.16.1. DEMO purpose

This demo includes the following functions of GD32 MCU:

- Learn to use EXMC control the NAND flash.

### 5.16.2. DEMO running result

GD32470I-EVAL board has EXMC module to control NAND flash. Before running the demo, JP5 must be fitted to USART. Download the program <16\_EXMC\_NandFlash> to the EVAL board. This demo shows the write and read operation process of NAND flash memory by EXMC module. If the test pass, LED1 will be turned on. Otherwise, turn on the LED3. Information via a HyperTerminal output as following:

```
NAND flash initialized!
Read NAND ID!
Nand flash ID:0xC8 0xF1 0x80 0x1D

Write data successfully!
Read data successfully!
Check the data!
Access NAND flash successfully!
The data to be read:
  0   1   2   3   4   5   6   7   8   9   a   b   c   d   e   f
10  11  12  13  14  15  16  17  18  19  1a  1b  1c  1d  1e  1f
20  21  22  23  24  25  26  27  28  29  2a  2b  2c  2d  2e  2f
30  31  32  33  34  35  36  37  38  39  3a  3b  3c  3d  3e  3f
40  41  42  43  44  45  46  47  48  49  4a  4b  4c  4d  4e  4f
50  51  52  53  54  55  56  57  58  59  5a  5b  5c  5d  5e  5f
60  61  62  63  64  65  66  67  68  69  6a  6b  6c  6d  6e  6f
70  71  72  73  74  75  76  77  78  79  7a  7b  7c  7d  7e  7f
80  81  82  83  84  85  86  87  88  89  8a  8b  8c  8d  8e  8f
90  91  92  93  94  95  96  97  98  99  9a  9b  9c  9d  9e  9f
a0  a1  a2  a3  a4  a5  a6  a7  a8  a9  aa  ab  ac  ad  ae  af
b0  b1  b2  b3  b4  b5  b6  b7  b8  b9  ba  bb  bc  bd  be  bf
c0  c1  c2  c3  c4  c5  c6  c7  c8  c9  ca  cb  cc  cd  ce  cf
d0  d1  d2  d3  d4  d5  d6  d7  d8  d9  da  db  dc  dd  de  df
e0  e1  e2  e3  e4  e5  e6  e7  e8  e9  ea  eb  ec  ed  ee  ef
f0  f1  f2  f3  f4  f5  f6  f7  f8  f9  fa  fb  fc  fd  fe  ff
```

## 5.17. SDIO\_SDCardTest

### 5.17.1. DEMO purpose

This demo includes the following functions of GD32 MCU:

- Learn to use SDIO to single block or multiple block write and read
- Learn to use SDIO to erase, lock and unlock a SD card

GD32470i-EVAL-V1.0 board has a secure digital input/output interface (SDIO) which defines the SD/SD I/O /MMC CE-ATA card host interface. This demo will show how to use SDIO to operate on SD card.

## 5.17.2. DEMO running result

Jump the JP5 to USART to show the print message through HyperTerminal, and jump the JP15 to LED3 to show the execution state of program. Download the program <17\_SDIO\_SDCardTest> to the EVAL board and run. Connect serial cable to COM0, open the HyperTerminal. Firstly, all the LEDs are turned on and off for test. Then initialize the card and print out the information of the card. After that, test the function of single block operation, lock and unlock operation, erase operation and multiple blocks operation. If any error occurs, print the error message and turn on LED1, LED3 and turn off LED2. Otherwise, turn on all the LEDs.

Uncomment the macro DATA\_PRINT to print out the data and display them through HyperTerminal. Set bus mode(1-bit or 4-bit) and data transfer mode(polling mode or DMA mode) by comment and uncomment the related statements.

Information via a serial port output as following.

```

Card init success!

Card information:
## Card version 3.0x ##
## SDHC card ##
## Device size is 7782400KB ##
## Block size is 512B ##
## Block count is 15564800 ##
## CardCommandClasses is: 5b5 ##
## Block operation supported ##
## Erase supported ##
## Lock unlock supported ##
## Application specific supported ##
## Switch function supported ##

Card test:
Block write success!
Block read success!
The card is locked!
Erase failed!
The card is unlocked!
Erase success!
Block read success!
Multiple block write success!
Multiple block read success!
  
```

## 5.18. CAN\_Network

### 5.18.1. DEMO purpose

This demo includes the following functions of GD32 MCU:

- Learn to use the CAN0 communication between two boards

GD32470I-EVAL board integrates CAN (controller area network) bus controller. It is a common industrial control bus. The CAN bus controller follows the 2.0A and 2.0B bus protocols. This routine demonstrates the communication between two boards through

---

CAN0.

### 5.18.2. DEMO running result

This example is tested with two GD32F470I-EVAL boards. Jump the JP5 to USART and JP19, JP21 to CAN with the jumper cap. Connect L pin to L pin and H pin to H pin of JP14 on the boards for sending and receiving frames. Download the program <18\_CAN\_Network> to the two EVAL boards, and connect serial cable to COM0. Firstly, the COM0 sends “please press the Tamper key to transmit data!” to the HyperTerminal. The frames are sent and the transmit data are printed by pressing Tamper Key push button. When the frames are received, the receive data will be printed and the LED2 will toggle one time.

The output information via the serial port is as following.

```
please press the Tamper key to transmit data!  
CAN0 transmit data: ab,cd  
CAN0 receive data: ab,cd
```

## 5.19. RCU\_Clock\_Out

### 5.19.1. DEMO purpose

This demo includes the following functions of GD32 MCU:

- Learn to use GPIO control the LED.
- Learn to use the clock output function of RCU.
- Learn to communicate with PC by USART.

### 5.19.2. DEMO running result

Jump the JP5 to USART with the jumper cap, and download the program <19\_RCU\_Clock\_Out> to the EVAL board and run. Connect serial cable to COM0, open the HyperTerminal. When the program is running, HyperTerminal will display the initial information. Then user can choose the type of the output clock by pressing the TAMPER button. After pressing, the corresponding LED will be turned on and HyperTerminal will display which mode be selected. The frequency of the output clock can be observed through the oscilloscope by PA8 and PC9 pin.

Information via a serial port output as following:

```
/===== Gigadevice clock output Demo =====/  
press tamper key to select clock output source  
CK_OUT0: IRC16M, CK_OUT1: system clock/5  
CK_OUT0: LXTAL, CK_OUT1: PLLI2SR/5
```

## 5.20. CTC\_Calibration

### 5.20.1. DEMO purpose

This demo includes the following functions of GD32 MCU:

- Learn to use external low speed crystal oscillator (LXTAL) to implement the CTC calibration function.
- Learn to use clock trim controller (CTC) to trim internal 48MHz RC oscillator (IRC48M) clock.

The CTC unit trim the frequency of the IRC48M based on an external accurate reference signal source. It can automatically adjust the trim value to provide a precise IRC48M clock.

### 5.20.2. DEMO running result

Download the program <20\_CTC\_Calibration > to the GD32470i-EVAL-V1.0 board and run. The LED1 will turn on if the internal 48MHz RC oscillator (IRC48M) clock trim is OK.

## 5.21. PMU\_Sleep\_Wakeup

### 5.21.1. DEMO purpose

This demo includes the following functions of GD32 MCU:

- Learn to use the USART receive interrupt to wake up the PMU from sleep mode

### 5.21.2. DEMO running result

Download the program < 21\_PMU\_Sleep\_Wakeup > to the EVAL board, jump the JP5 to USART with the jumper cap and connect serial cable to COM0. After power-on, all the LEDs are off. The mcu will enter sleep mode and the software stop running. When the USART0 receives a byte of data from the HyperTerminal, the mcu will wake up from a receive interrupt. And all the LEDs will flash together.

## 5.22. RTC\_Calendar

### 5.22.1. DEMO purpose

This demo includes the following functions of GD32 MCU:

- Learn to use RTC module to implement calendar function
- Learn to use USART module to implement time display

### 5.22.2. DEMO running result

Jump the JP5 to USART with the jumper cap, and download the program <22\_RTC\_Calendar> to the EVAL board and run. Connect serial cable to COM0, open the HyperTerminal. After start-up, the program will ask to set the time on the HyperTerminal. The calendar will be displayed on the HyperTerminal.

```
***** RTC calendar demo *****  
  
=====Configure RTC Time=====  
  
please input hour:  
  
12  
  
please input minute:  
  
12  
|  
please input second:  
  
12  
  
** RTC time configuration success! **  
  
Current time: 12:12:12
```

## 5.23. TIMER\_Breath\_LED

### 5.23.1. DEMO purpose

This demo includes the following functions of GD32 MCU:

- Learn to use Timer output PWM wave
- Learn to update channel value

### 5.23.2. DEMO running result

Use the DuPont line to connect the TIMER1\_CH2 (PB10) and LED1 (PE2), and then



download the program <23\_TIMER\_Breath\_LED> to the board and run. When the program is running, you can see LED1 lighting from dark to bright gradually and then gradually darken, just like breathing as rhythm.

## 5.24. TLI\_IPA

### 5.24.1. DEMO purpose

This demo includes the following functions of GD32 MCU:

- Learn to use TLI to control LCD for displaying different images
- Learn to use IPA to process image data

### 5.24.2. DEMO running result

Jump the JP12, JP15 to LCD, and download the program <24\_TLI\_IPA> to the EVAL board and run. After downloading program to board, a running cheetah on the background of GD logo is appeared on the LCD, which outputs as following. DC-5V power supply is recommended due to the large current consumption caused by LCD screen.

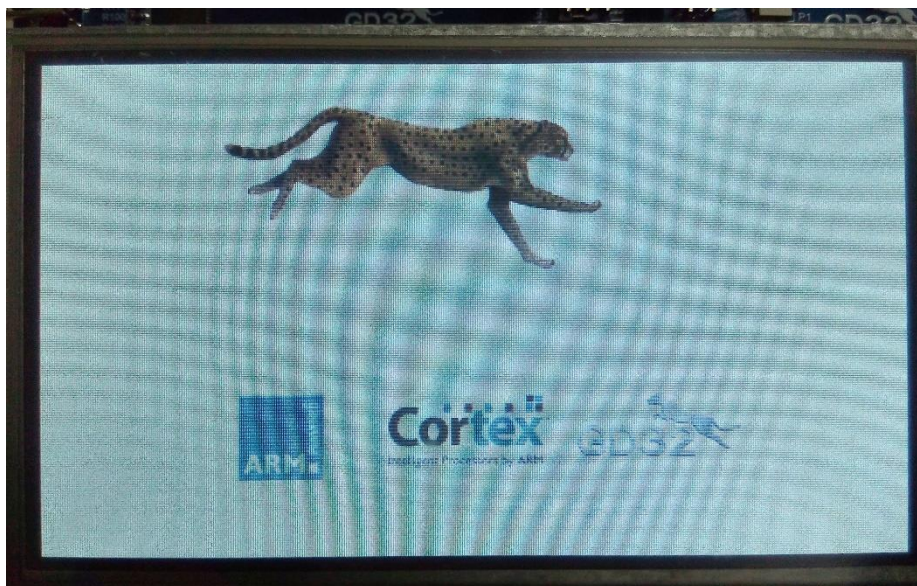

## 5.25. DCI\_OV2640

### 5.25.1. DEMO purpose

This demo includes the following functions of GD32 MCU:

- Learn to use DCI interface capture image from OV2640 camera
- Learn to use TLI interface display the captured image

## 5.25.2. DEMO running result

Connect jumper JP19,JP21,JP22,JP23 to DCI, jumper JP12 , JP15 to LCD, jumper JP17 to SDRAM. Download the program<25\_DCI\_OV2640>to the GD32470i-EVAL-V1.0 board, the correct installation of LCD display and OV2640 camera to the development board. After power on, you can observe the capture image of camera displayed on the LCD screen, you can press the user key to take photo and press tamper key to display photo. You can also return to the camera capture state when press the wakeup key on the development board.



## 5.26. TRNG\_Get\_Random

### 5.26.1. DEMO purpose

This demo includes the following functions of GD32 MCU:

- Learn to use TRNG generate the random number.
- Learn to communicate with PC by USART.

## 5.26.2. DEMO running result

Jump the JP5 to USART with the jumper cap, and download the program <26\_TRNG\_Get\_Random> to the EVAL board and run. Connect serial cable to COM0, open the serial terminal tool supporting hex format communication. When the program is running, the serial terminal tool will display the initial information. User can use the serial terminal tool to input the minimum and maximum values (for example, the minimum value is 0x00, the maximum value is 0x09), then application will generate random number in the input range and display it by the serial terminal tool.

Information via a serial port output as following:

```

/=====Gigadevice TRNG test=====/
TRNG init ok
Please input min num (hex format):
Please input max num (hex format):
Input min num is 0
Input max num is 9
Generate random num1 is 9
Generate random num2 is 8
Please input min num (hex format):

```

## 5.27. ENET

### 5.27.1. FreeRTOS\_tcpudp

#### DEMO purpose

This demo includes the following functions of GD32 MCU:

- Learn to use Lwip stack.
- Learn to use FreeRTOS operation system.
- Learn to use netconn and socket API to handle with a task.
- Learn how to realize a tcp server.
- Learn how to realize a tcp client.
- Learn how to realize a udp server/client.
- Learn how to use DHCP to allocate ip address automatically.

This demo is based on the GD32470i-EVAL-V1.0 board, it shows how to configure the enet peripherals to send and receive frames in normal mode and use lwip tcp / ip stack to realize ping, telnet and server/client functions.

JP12, JP13, JP17, JP18, JP20, JP22 must be fitted. JP5 jump to Usart.

It is configured in RMII mode, and 25MHz oscillator is used, the system clock is configured to 200MHz.

This demo realizes three applications:

- Telnet application, the eval board acts as tcp server. Users can link the client with

the eval board server, using 8000 port. Users can see the reply from the server, and can send the name(should input enter key) to server.

- tcp client application, the eval board acts as tcp client. Users can link the eval board client with the server, using 10260 port. Users can send information from server to client, then the client will send back the information.
- udp application. Users can link the eval board with another station, using 1025 port. Users can send information from station to board, then the board will send back the information.

If users need dhcp function, it can be configured from the private defines in main.h. This function is closed by default.

**Note:** Users should configure ip address, mask and gw of GD32470i-EVAL-V1.0 board or served according to the actual net situation from the private defines in main.h.

## DEMO running result

Download the program <FreeRTOS\_tcpudp> to the EVAL board, LED3 will light every 500ms.

Using Network assistant software, configure the pc side to tcp client, using 8000 port, and when send something through the assistant, users can see the reply from the server:

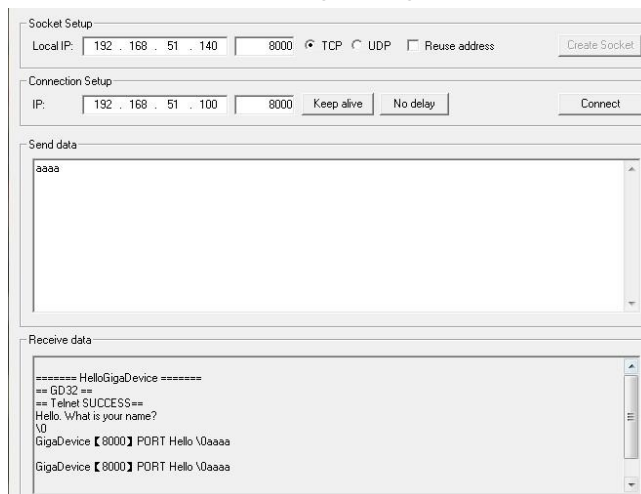

Using Network assistant software, configure the pc side to tcp server, using 10260 port, and when send something through the assistant, users can see the echo reply from the client:

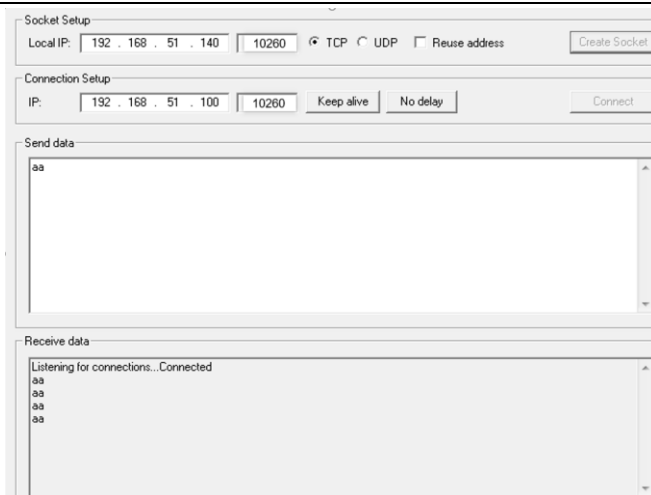

Using Network assistant software, configure to use udp protocol, using 1025 port, and when send something through the assistant, users can see the echo reply from the board:

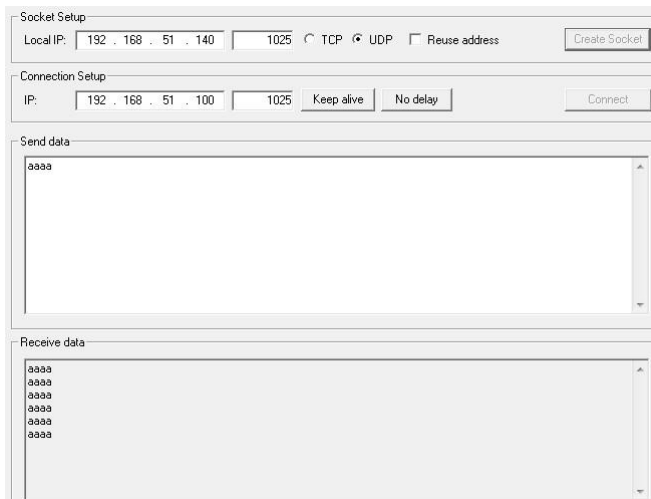

Open the DHCP function in main.h, using a router to connect the board with the pc, users can see the automatic allocated ip address of the board from the HyperTerminal.

## 5.27.2. Raw\_tcpudp

### DEMO purpose

This demo includes the following functions of GD32 MCU:

- Learn to use Lwip stack.
- Learn to use raw API to handle with a task.
- Learn how to realize a tcp server.
- Learn how to realize a tcp client.
- Learn how to realize a udp server / client.
- Learn how to use DHCP to allocate ip address automatically.
- Learn to handle with received packet in polling mode and in interrupt mode.



This demo is based on the GD32470i-EVAL-V1.0 board, it shows how to configure the enet peripherals to send and receive frames in normal mode and use lwip tcp / ip stack to realize ping, telnet and server/client functions.

JP12, JP13, JP17, JP18, JP20, JP22 must be fitted. JP5 jump to Usart.

It is configured in RMII mode, and 25MHz oscillator is used, the system clock is configured to 200MHz.

This demo realizes three applications:

- Telnet application, the eval board acts as tcp server. Users can link the client with the eval board server, using 8000 port. Users can see the reply from the server, and can send the name(should input enter key) to server.
- tcp client application, the eval board acts as tcp client. Users can link the eval board client with the server, using 10260 port. Users can send information from server to client, then the client will send back the information. If the server is not online at first, or is break during process, when the server is ready again, users can press tamper key to reconnect with server, and communicate.
- udp application. Users can link the eval board with another station, using 1025 port.
- Users can send information from station to board, then the board will send back the information.

By default, the packet reception is polled in while(1). If users want to receive packet in interrupt service, uncomment the macro defined USE\_ENET\_INTERRUPT in main.h. If users need dhcp function, it can be configured from the private defines in main.h. This function is closed in default.

Note: Users should configure ip address, mask and gw of GD32470i-EVAL-V1.0 board, or server according to the actual net situation from the private defines in main.h.

### **DEMO running result**

Download the program <Raw\_tcpudp> to the EVAL board.

Using Network assistant software, configure the pc side to tcp client, using 8000 port, and when send something through the assistant, users can see the reply from the server:

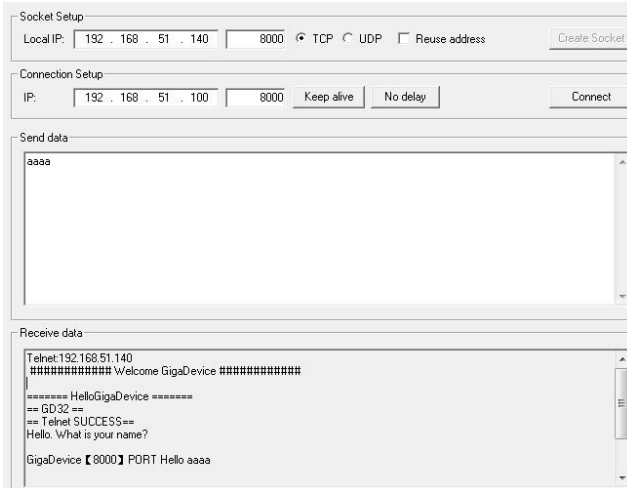

Using Network assistant software, configure the pc side to tcp server, using 10260 port, press the Tamper key, and when send something through the assistant, users can see the echo reply from the client:



Using Network assistant software, configure to use udp protocol, using 1025 port, and when send something through the assistant, users can see the echo reply from the board:

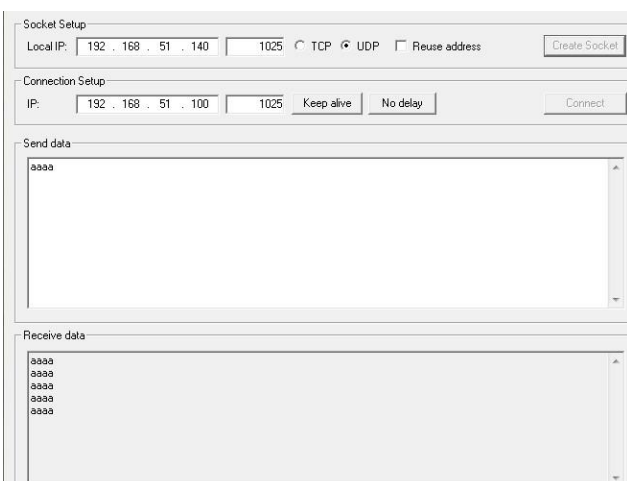

Open the DHCP function in main.h, using a router to connect the board with the pc, users can see the automatic allocated ip address of the board from the HyperTerminal.

### 5.27.3. Raw\_webserver

#### DEMO purpose

This demo includes the following functions of GD32 MCU:

- Learn to use Lwip stack.
- Learn to use raw API to handle with a task.
- Learn how to realize a web server.
- Learn how to use a web server to control LEDs.
- Learn how to use a web server to monitor the board  $V_{REFINT}$  voltage.
- Learn how to use DHCP to allocate ip address automatically.
- Learn to handle with received packet in polling mode and in interrupt mode.

This demo is based on the GD32470i-EVAL-V1.0 board, it shows how to configure the enet peripherals to send and receive frames in normal mode and use lwip tcp / ip stack to realize webserver application.

JP12, JP13, JP17, JP18, JP20, JP22 must be fitted. JP5 jump to Usart.

It is configured in RMII mode, and 25MHz oscillator is used, the system clock is configured to 200MHz.

This demo realizes webserver application:

Users can visit the eval board through Internet Explorer, the eval board acts as a webserver, and the url is the local ip address of the eval board. There are two experiments realized, one is the LEDs control, the other one is the ADC monitoring  $V_{REFINT}$  voltage in real-time.

If users need dhcp function, it can be configured from the private defines in main.h. This function is closed by default. Users can use a router to connect the eval board, and use the COM port to print the automatic allocated ip address, then connect your mobile phone to the wifi which the router send. Users can visit the eval board and control it on your mobile phone.

By default, the packet reception is polled in while(1). If users want to receive packet in interrupt service, uncomment the macro define USE\_ENET\_INTERRUPT in main.h.

Note: Users should configure ip address, mask and gw of GD32470i-EVAL-V1.0 board according to the actual net situation from the private defines in main.h.

#### DEMO running result

Download the program <Raw\_webserver> to the EVAL board, using Internet Explorer software, enter in the ip address of the board, click on the LED control linker, choose the



LED checkboxes users want to light, and “send”, the corresponding LEDs will light. Click on the ADC monitor linker, the real-time  $V_{REFINT}$  voltage is showed on the webpage, and the data refreshes every second automatically.

The web home page shows as below:

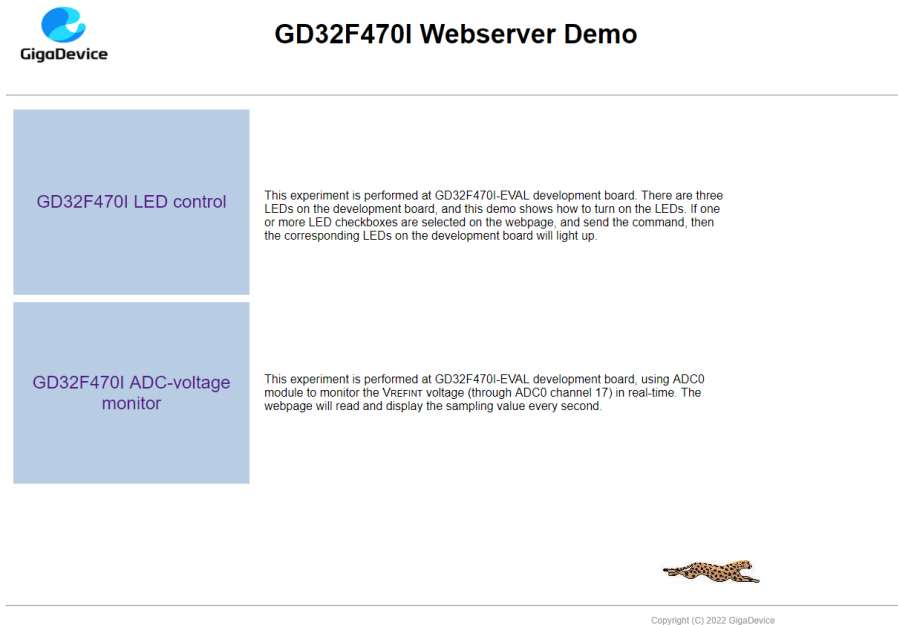

The LED control page shows as below:

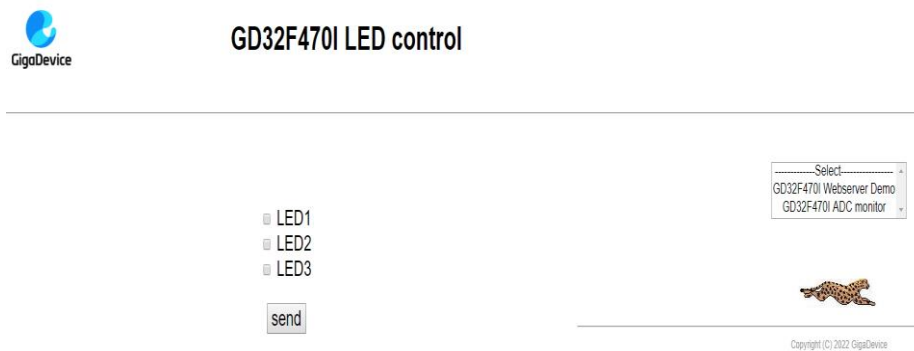

The ADC monitor page shows as below:



### GD32F470I ADC-voltage monitor

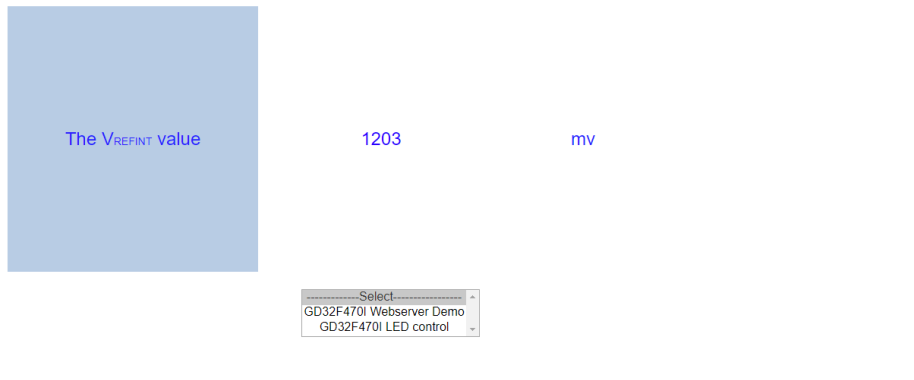

Copyright (C) 2022 GigaDevice

Open the DHCP function in main.h, using a router to connect the board, and use the HyperTerminal to print the automatic allocated ip address, then connect your mobile phone to the wifi which the router send. Users can visit the eval board and control it on your mobile phone.

## 5.28. USB\_Device

### 5.28.1. HID\_Keyboard

#### DEMO Purpose

This demo includes the following functions of GD32 MCU:

- Learn how to use the USBFS/USBHS peripheral mode
- Learn how to implement USB HID (human interface) device

GD32F470I-EVAL board has four keys, one USB\_FS interface and one USB\_HS interface. The four keys are Reset key, Wakeup key, User key and Tamper key. In this demo, the GD32F470I-EVAL board is enumerated as an USB Keyboard, which uses the native PC Host HID driver, as shown below. The USB Keyboard uses three keys (wakeup key, tamper key and user key) to output three characters ('b', 'a' and 'c'). In addition, the demo also supports remote wakeup which is the ability of a USB device to bring a suspended bus back to the active condition, and the wakeup key is used as the remote wakeup source.



## DEMO Running Result

According to the VBUSIG bit in USBFS\_GCCFG register, user can decide whether or not to jump JP5 to USB\_FS. After doing this, download the program <28\_USB\_Device\HID\_Keyboard> to the EVAL board and run. If you press the Wakeup key, will output 'b'. If you press the User key, will output 'c'. If you press the Tamper key, will output 'a'.

If you want to test USB remote wakeup function, you can do as follows:

- Manually switch PC to standby mode
- Wait for PC to fully enter the standby mode
- Push the Wakeup key
- If PC is ON, remote wakeup is OK, else failed.

### 5.28.2. MSC\_Udisk

#### DEMO Purpose

This demo includes the following functions of GD32 MCU:

- Learn how to use the USBFS/USBHS peripheral mode
- Learn how to implement USB MSC(mass storage) device

This demo mainly implements a U disk. U disk is currently very widely used removable MSC devices. MSC, the Mass Storage device Class, is a transport protocol between a computer and mobile devices, which allow a universal serial bus (USB) equipment to access a host computing device, file transfer between them, mainly including mobile hard disk, mobile U disk drive, etc... The MSC device must have a storage medium, and this Demo uses the MCU's internal SRAM as the storage medium. For more details of the MSC protocol please refer to the MSC protocol standard.

MSC device will use a variety of transport protocols and command formats for communication, so it need to choose the appropriate protocol and command format in the realization of the application. This Demo selects the BOT (bulk only transport) protocol and the required SCSI (small computer interface) command, and is compatible

with a wide variety of Window operating systems. Specific BOT protocol and SCSI command specification please refer to the standard of their agreement.

## DEMO Running Result

According to the VBUSIG bit in USBFS\_GCCFG register, user can decide whether or not to jump JP5 to USB\_FS if user use USBFS core. After doing this, download the program <28\_USB\_Device\MSC\_Udisk> to the EVAL board and run. When the EVAL board connect to the PC, you will find a USB large capacity storage device is in the universal serial bus controller, and there is 1 more disk drives in the equipment manager of PC, as shown below:

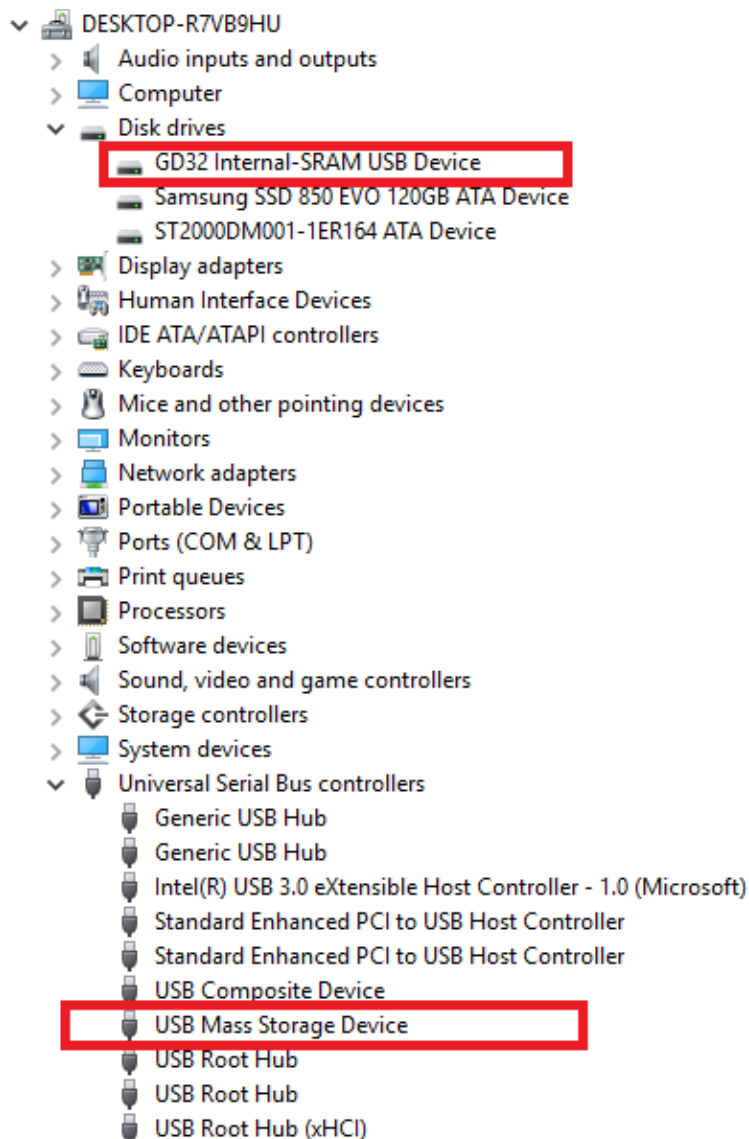

Then, after opening the resource manager, you will see more of the 1 disk, as shown in the following diagram:

### 有可移动存储的设备 (2)



At this point, the write/read/formatting operation can be performed as the other mobile devices.

## 5.29. USB\_Host

### 5.29.1. HID\_Host

#### DEMO Purpose

This demo includes the following functions of GD32 MCU:

- Learn to use the USBFS/USBHS as a HID host
- Learn the operation between the HID host and the mouse device
- Learn the operation between the HID host and the keyboard device

GD32F470I-EVAL board integrates the USBFS and USBHS module, and the module can be used as USB device, USB host or OTG device. This demo mainly shows how to use the USBFS/USBHS as a USB HID host to communicate with external USB HID device.

#### DEMO Running Result

Jump the JP5 to USB\_FS and jump the JP17 to SDRAM. Insert the OTG cable to USB port. Then, download the program <29\_USB\_Host\HID\_Host> to the EVAL board and run.

If a mouse has been attached, the user will see the information of mouse enumeration.

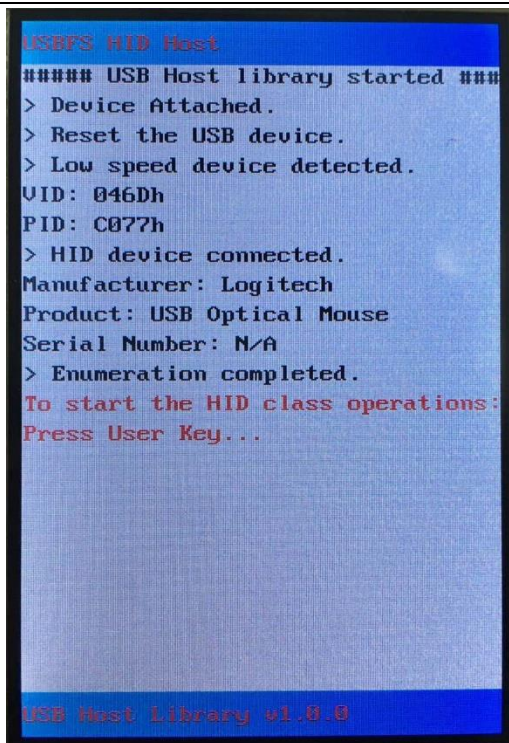

First pressing the user key will see the inserted device is mouse, and then moving the mouse will move the 'x' in the LCD screen and pressing the button will show the magenta color rectangle in the LCD screen.

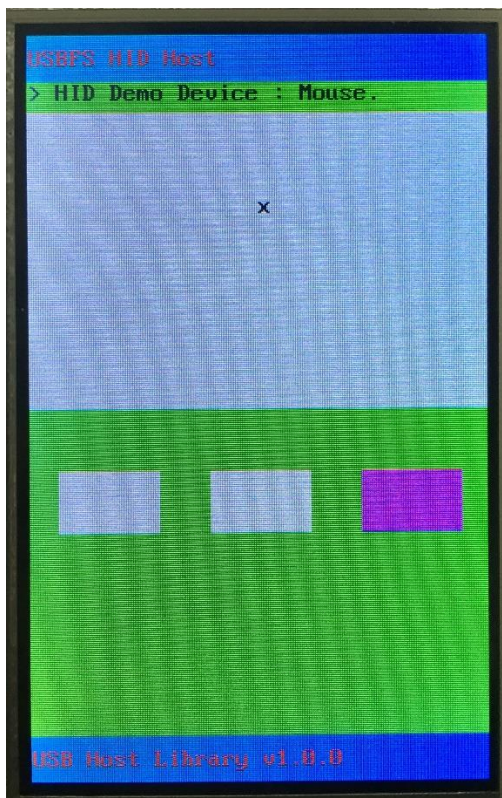



If a keyboard has been attached, the user will see the information of keyboard enumeration.

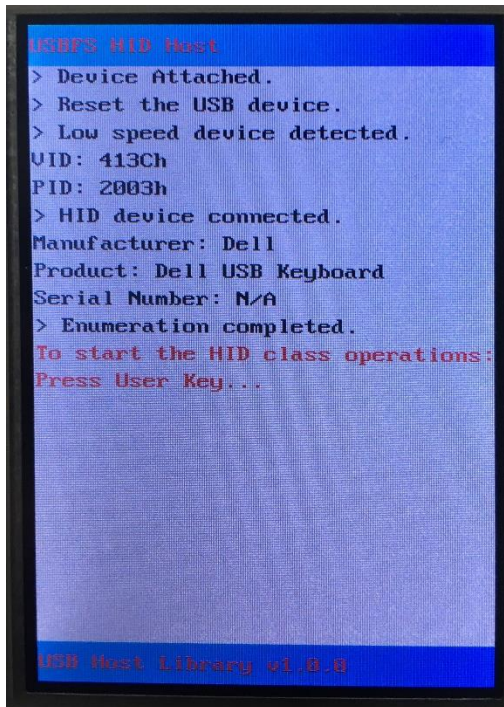

First pressing the user key will see the inserted device is keyboard, and then pressing the keyboard will print the char of the button in the LCD screen.

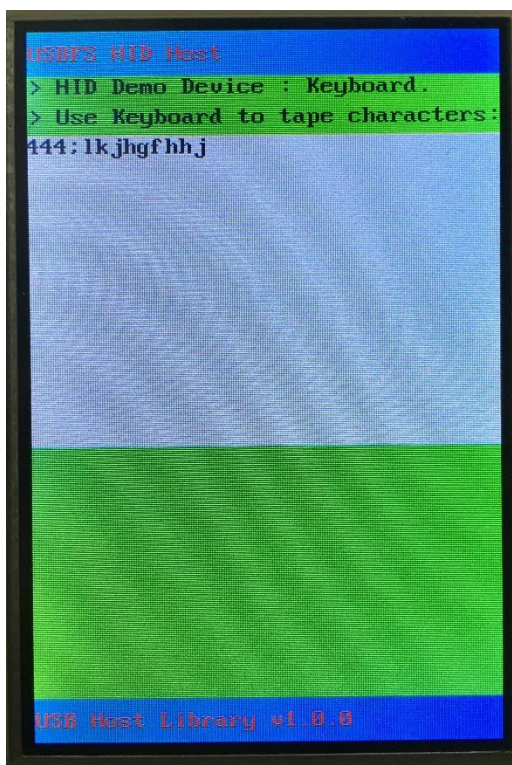

## 5.29.2. MSC\_Host

### DEMO Purpose

This demo includes the following functions of GD32 MCU:

- Learn to use the USBFS/USBHS as a MSC host
- Learn the operation between the MSC host and the Udisk

GD32F470I-EVAL board integrates the USBFS and USBHS module, and the modules can be used as USB device, USB host or OTG device. This demo mainly shows how to use the USBFS or the USBHS as a USB MSC host to communicate with external Udisk.

### DEMO Running Result

Jump the JP5 to USB\_FS and jump the JP17 to SDRAM. Insert the OTG cable to USB port. Then, download the program <29\_USB\_Host\HID\_Host> to the EVAL board and run.

If an Udisk has been attached, the user will see the information of Udisk enumeration.

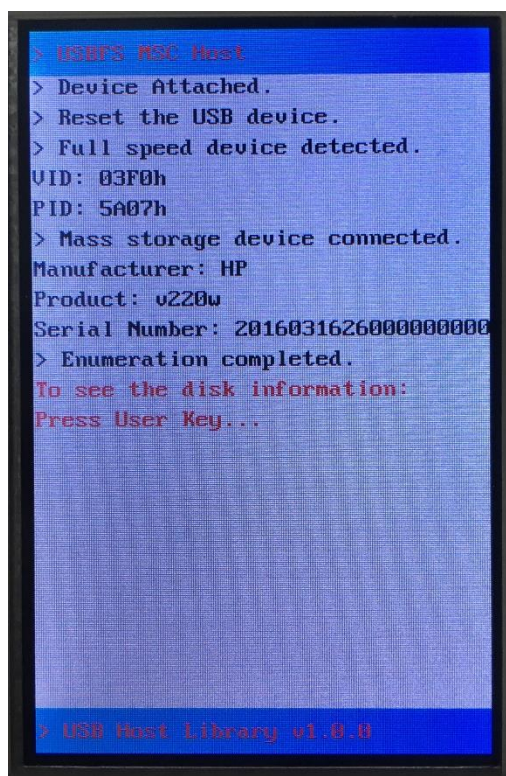

```

> USBFS MSC Host
> Device Attached.
> Reset the USB device.
> Full speed device detected.
VID: 03F0h
PID: 5A07h
> Mass storage device connected.
Manufacturer: HP
Product: v220w
Serial Number: 201603162600000000
> Enumeration completed.
To see the disk information:
Press User Key...

> USB Host Library v1.0.0
  
```

First pressing the user key will see the Udisk information, next pressing the tamper key will see the root content of the Udisk, then press the wakeup key will write file to the Udisk, finally the user will see information that the msc host demo is end.



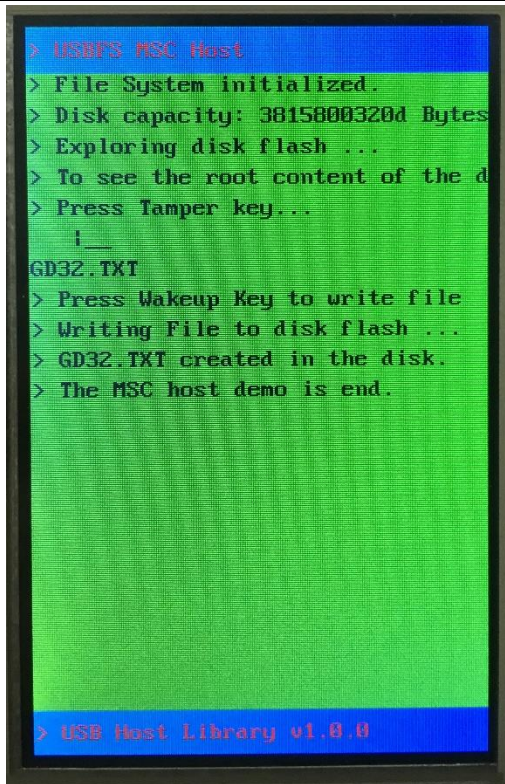

## 6. Revision history

Table 6-1 Revision history

Revision No.	Description	Date
2.0	Initial Release	April.18, 2022

## Important Notice

This document is the property of GigaDevice Semiconductor Inc. and its subsidiaries (the "Company"). This document, including any product of the Company described in this document (the "Product"), is owned by the Company under the intellectual property laws and treaties of the People's Republic of China and other jurisdictions worldwide. The Company reserves all rights under such laws and treaties and does not grant any license under its patents, copyrights, trademarks, or other intellectual property rights. The names and brands of third party referred thereto (if any) are the property of their respective owner and referred to for identification purposes only.

The Company makes no warranty of any kind, express or implied, with regard to this document or any Product, including, but not limited to, the implied warranties of merchantability and fitness for a particular purpose. The Company does not assume any liability arising out of the application or use of any Product described in this document. Any information provided in this document is provided only for reference purposes. It is the responsibility of the user of this document to properly design, program, and test the functionality and safety of any application made of this information and any resulting product. Except for customized products which has been expressly identified in the applicable agreement, the Products are designed, developed, and/or manufactured for ordinary business, industrial, personal, and/or household applications only. The Products are not designed, intended, or authorized for use as components in systems designed or intended for the operation of weapons, weapons systems, nuclear installations, atomic energy control instruments, combustion control instruments, airplane or spaceship instruments, transportation instruments, traffic signal instruments, life-support devices or systems, other medical devices or systems (including resuscitation equipment and surgical implants), pollution control or hazardous substances management, or other uses where the failure of the device or Product could cause personal injury, death, property or environmental damage ("Unintended Uses"). Customers shall take any and all actions to ensure using and selling the Products in accordance with the applicable laws and regulations. The Company is not liable, in whole or in part, and customers shall and hereby do release the Company as well as its suppliers and/or distributors from any claim, damage, or other liability arising from or related to all Unintended Uses of the Products. Customers shall indemnify and hold the Company as well as its suppliers and/or distributors harmless from and against all claims, costs, damages, and other liabilities, including claims for personal injury or death, arising from or related to any Unintended Uses of the Products.

Information in this document is provided solely in connection with the Products. The Company reserves the right to make changes, corrections, modifications or improvements to this document and Products and services described herein at any time, without notice.