

7128 Copper channel style heat sink with integrated clip

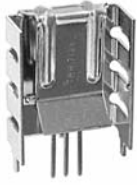

Copper channel style heat sink with integrated clip and locking tab for secure attachment to the device. Narrow profile uses less board space. Includes tin plated solderable tabs for easy attachment to the printed circuit card.

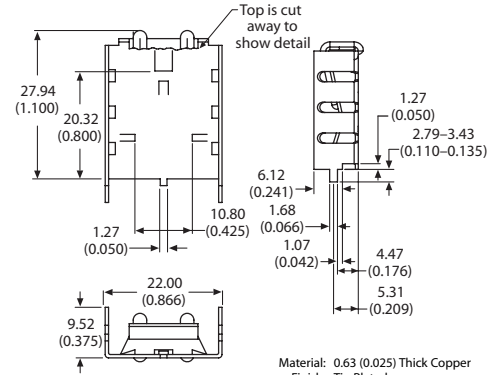
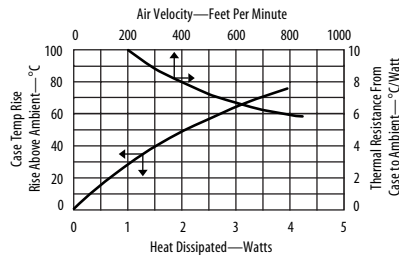

ORDERING INFORMATION

Part Number	Description	Dia of PCB Plated Thru Hole for Tabs
7128DG	Slide on channel heat sink with integrated clip and locking tabs	2.92 (0.115)

6038 Channel style heat sink with integrated clip



Channel style heat sink with integrated clip and locking tab for secure attachment to the device. Tabs can be bent for mounting.

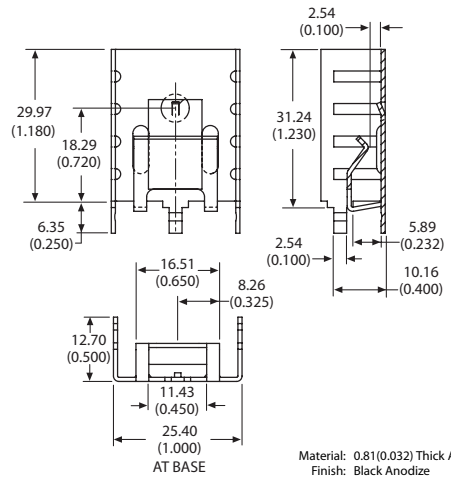
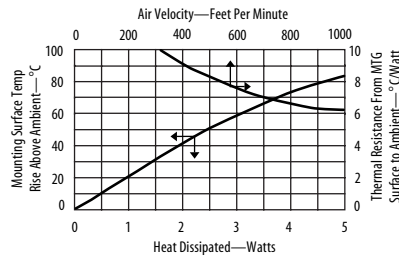

ORDERING INFORMATION

Part Number	Description	Dia of PCB Plated Thru Hole for Tabs
6038BG	Slide on channel heat sink with integrated clip and locking tabs	3.81 (0.150)

7142 Narrow channel style heat sink with integrated clip



Narrow channel style heat sink with integrated clip and locking tab for secure attachment to the device. Device can be mounted horizontally using a single center tab that can be soldered directly to the PC board.

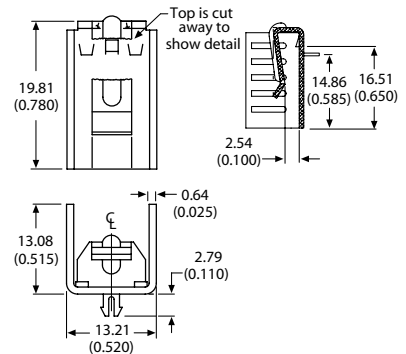
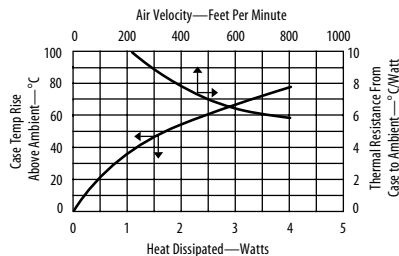

ORDERING INFORMATION

Part Number	Description	Dia of PCB Plated Thru Hole for Tabs
7142DG	Slide on narrow channel heat sink with integrated clip and locking tabs	3.18 (0.125)