

RoHS

REV.	EC#	DESCRIPTION	DATE	DRAWING	CHECKED	APPROVED
A0		NEW RELEASE	2018.04.20	Michael	Mark	Cornelia

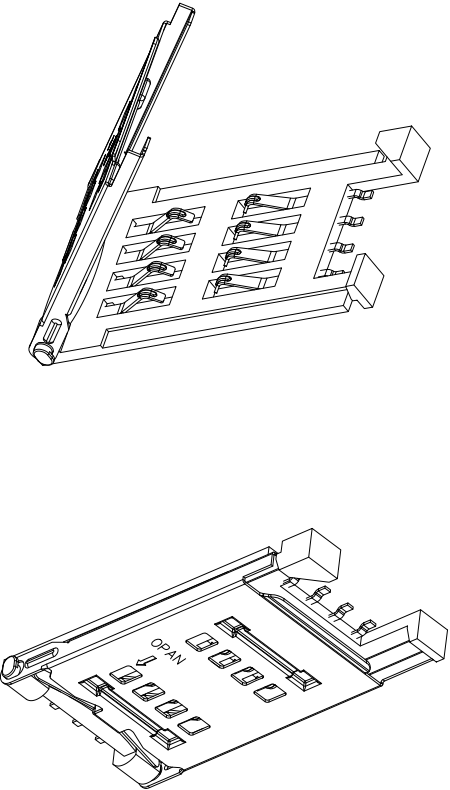

PCB LAYOUT RECOMMENDED

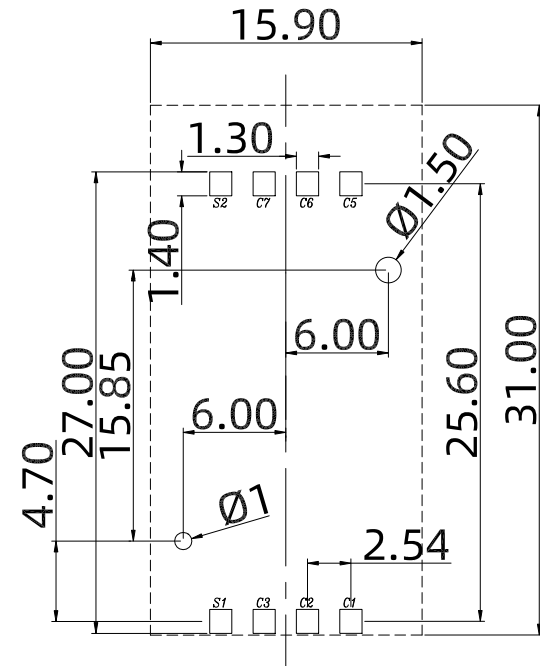
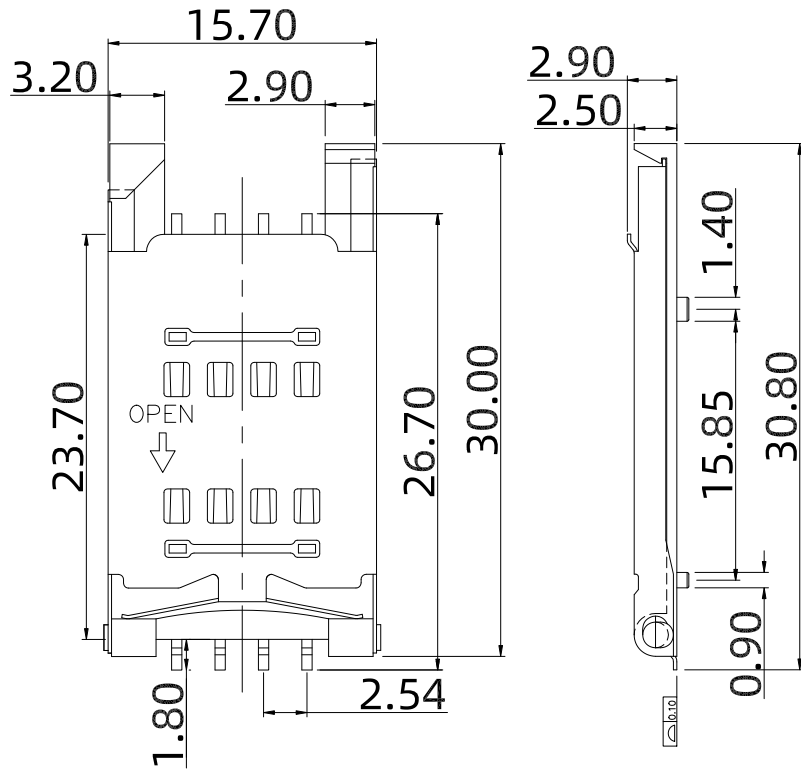
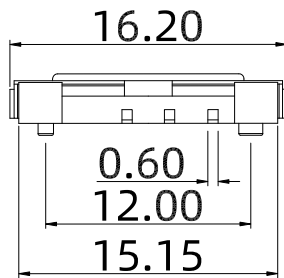

SIM Card Connector, With Cover, Type 1,8 Pin
 Physical:
 Housing: LCP UL 94V-0
 Contact: Selective Gold Flash
 Specifications:

Voltage Current rating: 1A, 50V AC
 Insulation Resistance: 1000Mohm
 Min Contact Withstanding Voltage: AC 500V For 1 Minute
 Temperature Rating: -40° To +85°

MILLIMETERS	INCH	UNITS	WELCONN® 深圳市微连电子有限公司 ShenZhen Welink Electronics Co.,Ltd			
X.° ± 2°	X.° ± 2°	MM	PART NUMBER:		TITLE:	
.X ± 0.30	.XX ± 0.012	MAT'L SEE NOTES	WL-SIM180-098		SIM卡座 翻盖式 6P 2.9H 铁盖	
.XX ± 0.20	.XXX ± 0.008	FINISH SEE NOTES	DWG NO.:		APPD: Cornelia	
.XXX ± 0.10	.XXXX ± 0.004	QTY SEE NOTES	WL-SIM180-098		CHKD: Mark	
THESE DRAWINGS AND SPECIFICATION ARE Welink ShenZhen Welink Electronics Co.,Ltd COPIED OR USED IN ANY MANNER WITHOUT Welink ShenZhen Welink Electronics Co.,Ltd			SCALE	SHEET	REV.	
			1:1	2/2	A1	
			DR: Michael			

RoHS

REV.	EC#	DESCRIPTION	DATE	DRAWING	CHECKED	APPROVED
A0		NEW RELEASE	2018.04.20	Michael	Mark	Cornelia

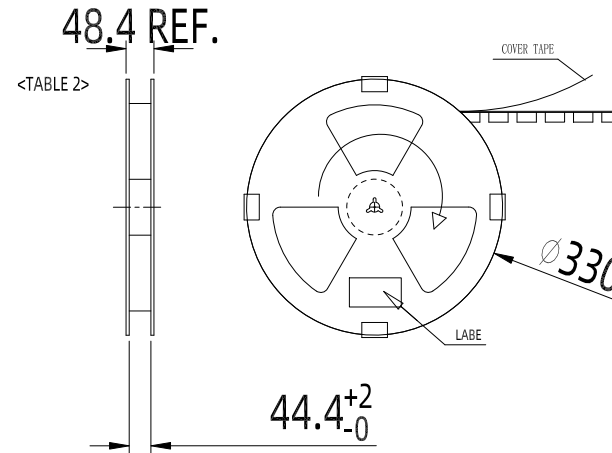
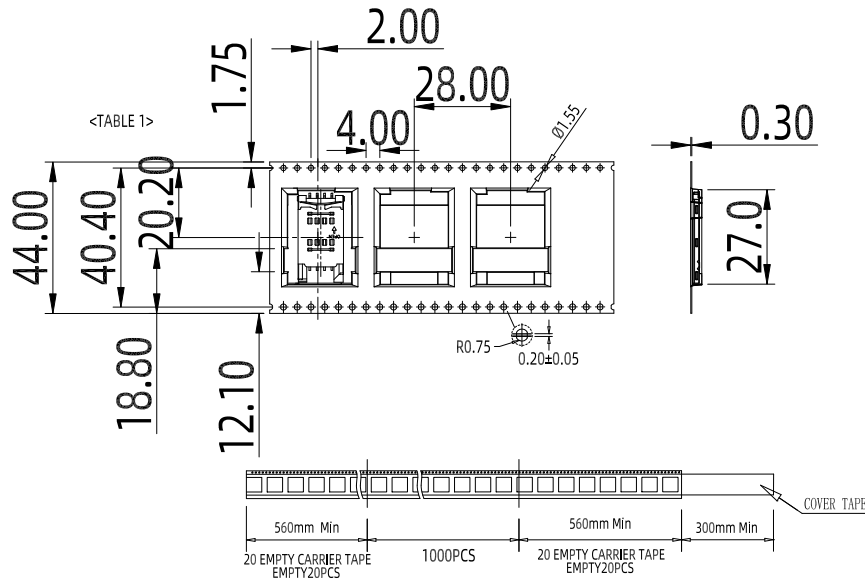

<TABLE 1> PACKAGING QUANTITY

QTY/REEL	REEL/CARTON	QTY/CARTON
1000	6	6000

COVER TAPE PEELING FORCE: 20gf~120gf

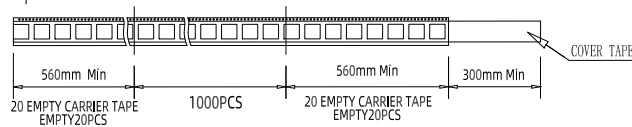
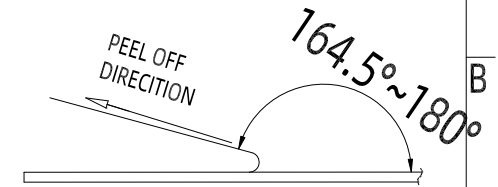

<TABLE 3>

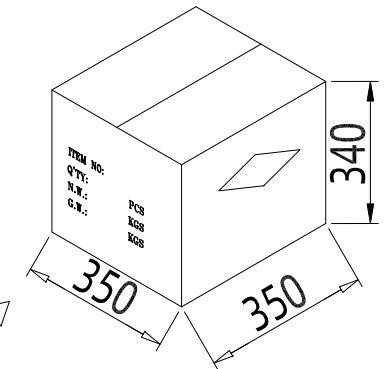
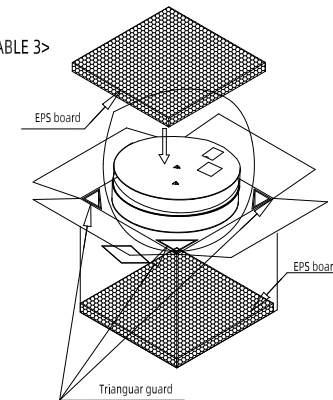

NOTE:

1. Place 1 PCS product per hole according to <Figure 1>.
 2. After the packaging machine is wrapped, stick tape on each equal point of the REEL to prevent the REEL from scattered. label each REEL, as shown in <Figure 2>
 3. The packaging quantity is shown as <TABLE 1>
 4. Package, as shown in <Figure 3>
- Put the EPS board at the bottom of the box, and then put the REEL into the box. Put four triangular guards into the four corners, and put the EPS board on the top.
5. Seal the box, write the material number, quantity, etc. on the sealed carton according to customer requirements

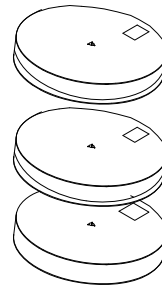

MILLIMETERS	INCH	UNITS	WECONN® 深圳市微连电子有限公司 ShenZhen Welink Electronics Co.,Ltd			
X° ± 2°	X° ± 2°	MM	PART NUMBER: WL-SIM180-098		TITLE: SIM卡座 翻盖式 6P 2.9H 铁盖	
.X ± 0.30	.XX ± 0.012	MAT'L SEE NOTES	DWG NO.: WL-SIM180-098		APPD:	Cornelia
.XX ± 0.20	.XXX ± 0.008	FINISH SEE NOTES	SCALE	SHEET	REV.	CHKD: Mark
.XXX ± 0.10	.XXXX ± 0.004	QTY SEE NOTES	1:1	2/2	A1	DR: Michael
THESE DRAWINGS AND PECIFICATION ARE Welink ShenZhen Welink Electronics Co.,Ltd COPIED OR USED IN ANY MANNER WITHOUT Welink ShenZhen Welink Electronics Co.,Ltd						