

10.1" P-Cap Chassis Display - W10L100-PCH2-PoE

Features

- 10.1" 1280 x 800 Resolution
- Projected Capacitive Multi-Touch (P-Cap)
- Front IP65 Water and Dust Proof
- VGA input and variety of optional connectors
- USB port for touch
- Stylish and elegant design
- Support PoE

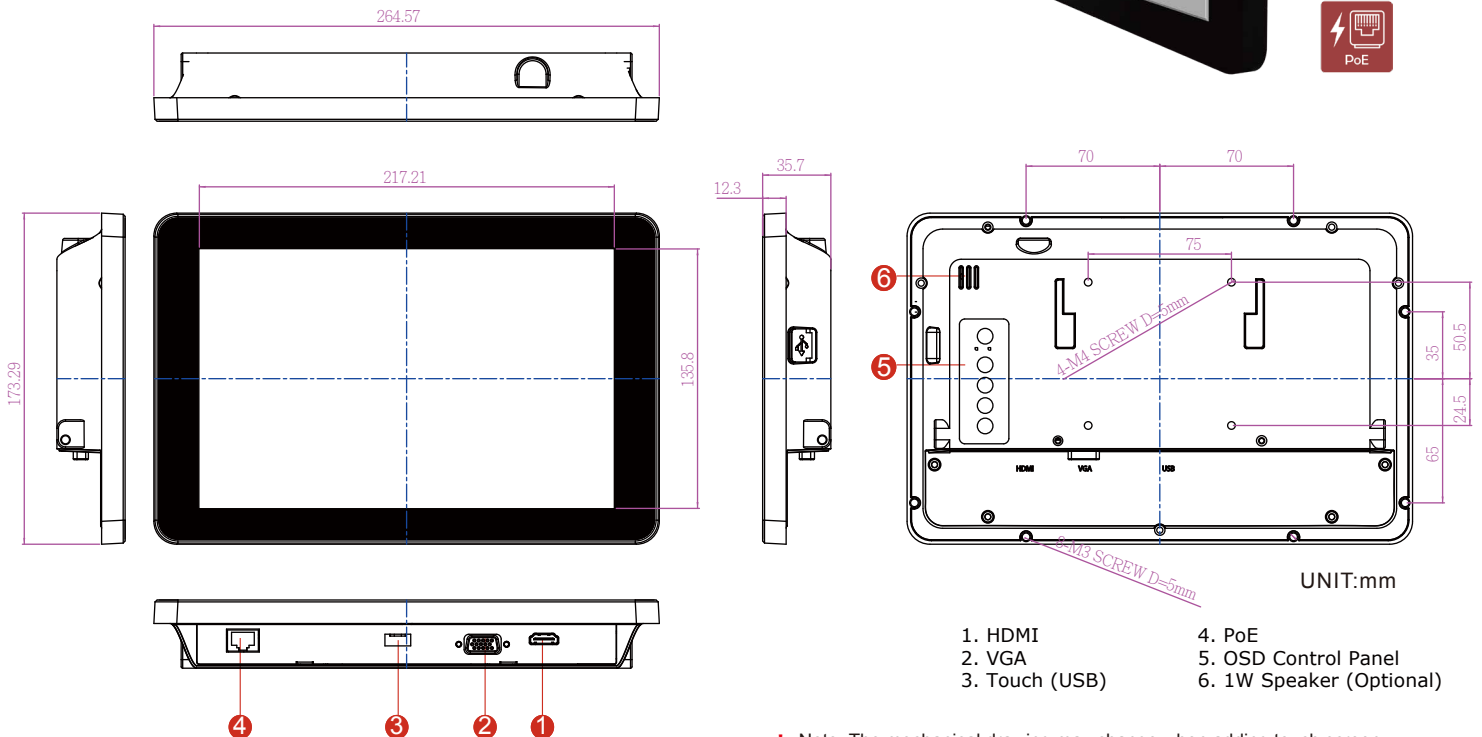

* Note: The mechanical drawing may change when adding touch screen. Please contact our sales representative if you need further product information.

Specifications

Display

- Panel Size : 10.1"
- Active Display Area(mm) : 216.96 (H) x 135.6 (V)
- Resolution : 1280 x 800
- Brightness(cd/m2) : 350 (Typical)
- Contrast Ratio : 800:1 (Typical)
- Viewing Angles(CR>=10 L/R/U/D) : -85~85(H) ; -85~85(V)
- Display Colors : 16.7M (8 bits/color)
- Standard Input Signal : 1 x VGA (D-sub 15)
1 x HDMI (Type-A)

Power Considerations

- Power Input/Power Over Ethernet : Power Device (PD) follows IEEE 802.3at (25 W), IEEE 802.3af (15 W)
- Power Consumption : 10W typical , Normal operation

Environment

- Operating temperature : 0~50°C
- Storage Temperature : -10~60°C
- IP Rating : Front IP65
- Certifications : CE, FCC

Output

- Touch Screen : Projected Capacitive Touch (USB)
Protective Glass (Optional)
Optional anti-glare coating
- Speakers (Optional) : 1 x Speaker
- OSD : 5 Keys: - , + , Power , Esc , Enter

Accessories

- Accessories : VGA cable (1.8m)
HDMI cable (2m)

*Outside dimension and I/O will be different from standard