

REV	ECN No.	DESCRIPTION	DESIGN	DATE
AO		Release		

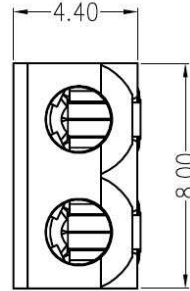

主要技术参数 Main Specifications

线 数 (Poles): 01 to 03P
 接触电阻 (Contact resistance): $\leq 20m\Omega$
 绝缘电阻 (Insulation resistance): $\geq 800M\Omega$
 额定电压 (Rated voltage): 275V AC DC
 额定电流 (Rated current): 6.0A AC DC
 耐 电 压 (Withstand Voltage): 800V AC/minute
 温度范围 (Temperature Range): $-40^{\circ}C \sim +130^{\circ}C$

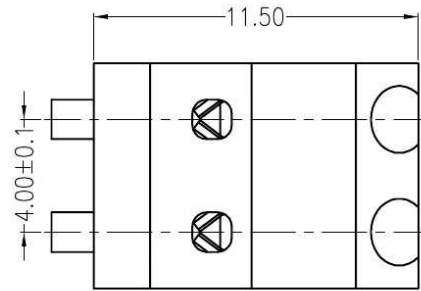
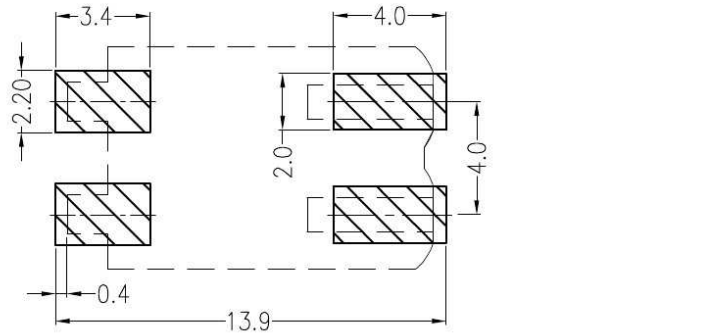
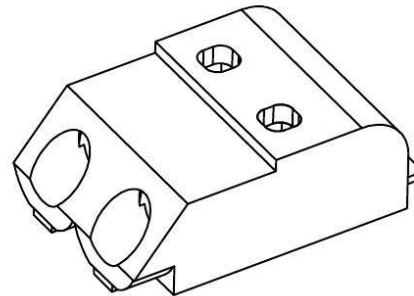
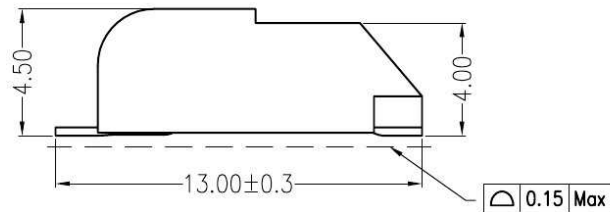

Board Layout

C					
B	CONTACT		2 PCS	PhosphorBronze	MATTE Sn-plated
A	HOUSING		2 PCS	LCP	UL 94V-0, COLOR:BEIGE
ITEM	COMPONENT		Q'TY	MATERIAL	FINISH
LEDsconn					TITLE: - 4.0mmPITCH 90°WAFER SMT TYPE
X.±0.5	X.±5'	USE:	CUSTOMER		PART NO.:
.X±0.3	.X±2'	APPD:			
.XX±0.25	.XX±1'	CHKD:			DWG NO.:
--	--	DR:			SCALE 1 : 1
		UNITS: mm			SHEET 1 / 1