

**SFP-XCxxHM0xDL40**

## 10.3Gb/s XFP CWDM Transceiver

**SFP-XCxxHM0xDL40****■ Product Features**

- ✓ Supports 9.95 to 11.3Gb/s
- ✓ Duplex LC connector
- ✓ Hot-pluggable XFP footprint
- ✓ Cooled 1550nm EML laser
- ✓ RoHS compliant and Lead Free
- ✓ 40Km link length
- ✓ Metal enclosure for lower EMI
- ✓ Built-in dual CDR
- ✓ +5.0V and +3.3V power supply and power dissipation <2.5W
- ✓ XFP MSA INF-80771 Compliant
- ✓ XFI loop-back Support

**■ Applications**

- ✓ CWDM Networks
- ✓ 10GBASE-ER/EW

**■ General**

SFP-XCxxHM0xDL40 Small Form Factor 10Gb/s XFP transceivers are compatible with XFP MSA Specification. They comply with SONET OC-192 IR-2, OC-192 IR-3, SDH STM S-64.2b, STM S-64.3b as well as with 10G Ethernet 10G BASE-ER/EW per IEEE802.3ae and 40km 10G Fibre Channel applications.

**■ Product Selection**

Part Number	Operating Case temperature	DDMI
SFP-XCxxHM0CDL40	Commercial(0~70°C)	Yes
SFP-XCxxHM0EDL40	Extend(0~85°C)	Yes
SFP-XCxxHM0IDL40	Industrial(-40~85°C)	Yes

**■ Product Channel Selection**

**SFP-XCxxHM0xDL40**

Part Number	Wavelength	Data Rate	Distance
SFP-XC47HM0xDL40	1471nm EML	9.95G~11.3G	40KM
SFP-XC49HM0xDL40	1491nm EML	9.95G~11.3G	40KM
SFP-XC51HM0xDL40	1511nm EML	9.95G~11.3G	40KM
SFP-XC53HM0xDL40	1531nm EML	9.95G~11.3G	40KM
SFP-XC55HM0xDL40	1551nm EML	9.95G~11.3G	40KM
SFP-XC57HM0xDL40	1571nm EML	9.95G~11.3G	40KM
SFP-XC59HM0xDL40	1591nm EML	9.95G~11.3G	40KM
SFP-XC61HM0xDL40	1611nm EML	9.95G~11.3G	40KM

### ■ Regulatory Compliance

- ESD to the Electrical PINs: compatible with MIL-STD-883 Method 3015
- ESD to the Duplex LC Receptacle: compatible with IEC 61000-4-2
- Immunity compatible with IEC 61000-4-3
- EMI compatible with FCC Part 15 Class B EN55022 Class B (CISPR 22B) VCCI Class B
- Laser Eye Safety compatible with FDA 21CFR 1040.10 and 1040.11 EN60950, EN (IEC) 60825-1,2
- ROHS compliant with ROHS 2 (2011/65/EU)

### ■ Pin Descriptions

Pin	Symbol	Name/Description	Ref.
1	GND	Module Ground	
2	VEE5	Optional -5.2 Power Supply – Not required	
3	MOD_DESEL	Module De-select; When held low allows the module to respond to 2-wire serial interface. LVTTTL-I	
4	/INTERRUPT	Interrupt; Indicates presence of an important condition which can be read via the 2-wire serial interface. LVTTTL-O	2
5	TX_DIS	Transmitter Disable. Logic1 indicates laser output disabled, LVTTTL-I	
6	VCC5	+5V Power Supply	
7	GND	Module Ground	1

**SFP-XCxxHM0xDL40**

8	VCC3	+3.3V Power Supply	
9	VCC3	+3.3V Power Supply	
10	SCL	2-Wire Serial Interface Clock. LVTTTL-I	2
11	SDA	2-Wire Serial Interface Data Line. LVTTTL-I/O	2
12	MOD_Abs	Indicates Module is not present. Grounded in the Module. LVTTTL-O	2
13	MOD_NR	Module Not Ready; Indicating Module Operational Fault. Open-collector. LVTTTL-O	2
14	RX_LOS	Loss of Signal indication. Logic 1 indicates loss of Signal. Open-collector. LVTTTL-O	2
15	GND	Module Ground	1
16	GND	Module Ground	1
17	RD-	Receiver Inverted Data Output. CML-O	
18	RD+	Receiver Non-Inverted Data Output. CML-O	
19	GND	Module Ground	1
20	VCC2	+1.8V Power Supply (Not required).	3
21	P_DOWN/R	Power down; When high, requires the module to limit power consumption to 1.5W or below. 2-Wire serial interface must be functional in the low power mode. LVTTTL-I	
	ST	Reset; The falling edge initiates a complete reset of the module including the 2-wire serial interface, equivalent to a power cycle. LVTTTL-I	
22	VCC2	+1.8V Power Supply (Not required)	3
23	GND	Module Ground	1
24	REFCLK+	Reference Clock (Not required)	
25	REFCLK-	Reference Clock (Not required)	
26	GND	Module Ground	1
27	GND	Module Ground	1
28	TD-	Transmitter Inverted Data Input. CML-I	
29	TD+	Transmitter Non-Inverted Data Input. CML-I	
30	GND	Module Ground	1

**Notes:**

# SFP-XCxxHM0xDL40

1. Module ground pins GND are isolated from the module case and chassis ground within the module.
2. Open collector; Should be pulled up with 4.7K-10Kohms to a voltage between 3.15V and 3.6V on the host board.
3. The pins are open within module.

## Pin-out Connector Block on Host Board

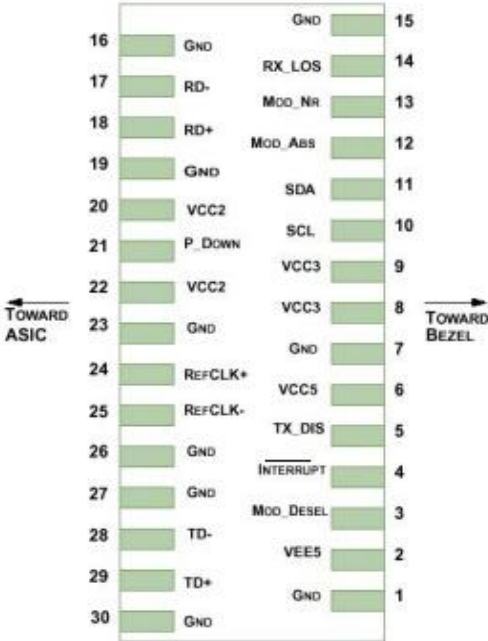

Pin-out of Connector Block on Host Board

## Recommend Circuit Schematic

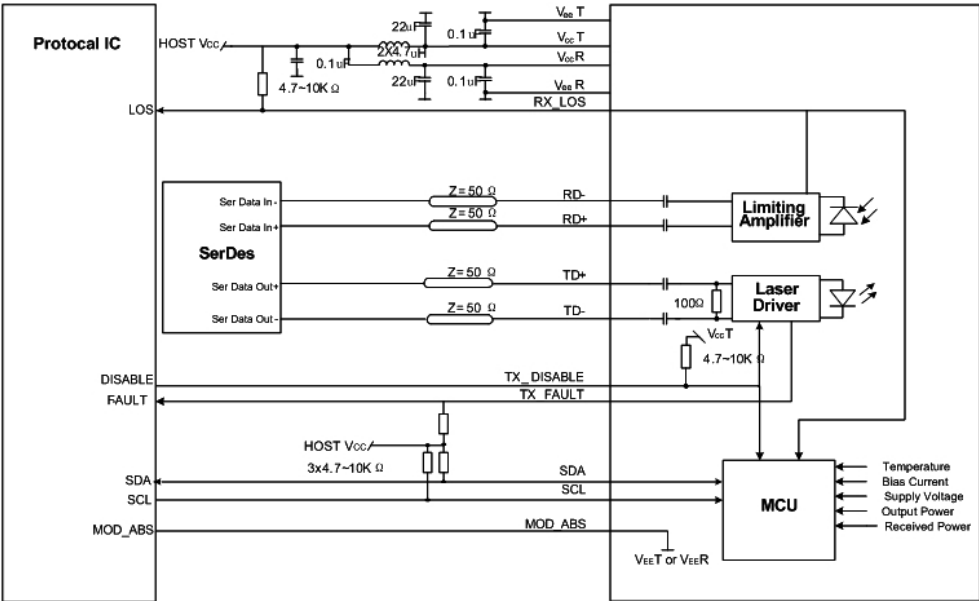

## Absolute Maximum Ratings

**SFP-XCxxHM0xDL40**

Parameter	Symbol	Min	Typ	Max	Unit	Ref.
Maximum Supply Voltage	Vcc3	-0.5		+4.0	V	
	Vcc5	-0.5		+6.0	V	
Storage Temperature	TS	-40		+85	°C	
Operating Humidity	RH	0		85	%	

### ■ Recommended Operating Conditions

Parameter	Symbol	Min	Typ	Max	Unit	Ref.
Power Supply Voltage	Vcc3	3.13	3.30	3.47	V	
	Vcc5	4.75	5.0	5.25	V	
Power Supply Current	Icc3			600	mA	
	Icc5			100	mA	
Case Operating Temperature	Tc	0		+70	°C	Commercial
	Te	0		+85		Extend
	Tl	-40		+85		Industrial
Bit Rate	Br	9.95		11.3	Gbps	
9/125um G.652 SMF	Lmax			40	km	

### ■ Electrical Characteristics (TOP=25°C, Vcc3=3.3Volts)

Parameter	Symbol	Min	Typ	Max	Unit	Ref.
<b>Transmitter</b>						
Input differential impedance	Rin	80	100	120	Ω	1
Differential data input swing	Vin, pp	120		850	mV	
TX Disable-High		Vcc – 0.8		Vcc	V	
TX Disable-Low		Vee		Vee+ 0.8	V	
TX Fault-High		Vcc-0.8		Vcc	V	
TX Fault-Low		Vee		Vee+0.8	V	
<b>Receiver</b>						
Single ended data output swing	Vout, pp	300		850	mV	2
Data output rise time	Tr	30			ps	3

**SFP-XCxxHM0xDL40**

Data output fall time	Tf	30			ps	3
LOS-High		Vcc – 0.8		Vcc	V	
LOS-Low		Vee		Vee+0.8	V	

**Notes:**

1. AC coupled.
2. Into 100 ohm differential termination.
3. 20 – 80 %

■ **Optical Characteristics (TOP=25°C, Vcc3=3.3 Volts)**

Parameter	Symbol	Min	Typ	Max	Unit	Ref.
<b>Transmitter</b>						
Output Opt. Power	PO	-1		4	dBm	
Optical Wavelength	$\lambda$	$\lambda - 6.5$		$\lambda + 6.5$	nm	
Side-Mode Suppression Ratio	SMSR	30			dB	
RMS Spectral Width(-20dB)	$\sigma$			1	nm	
Optical Extinction Ratio	ER	8.2			dB	
Path penalty at 800ps/nm@9.95Gb/s				2	dB	
Relative Intensity Noise	RIN			-128	dB/Hz	
<b>Receiver</b>						
RX Sensitivity @10.3 Gb/s	SENS			-16	dBm	1,2
Receiver Overload		-1			dBm	
Optical Center Wavelength	$\lambda_C$	1260		1620	nm	
LOS De-Assert	LOSD			-20	dBm	
LOS Assert	LOSA	-34			dBm	
LOS Hysteresis		0.5			dB	

**Notes:**

1. Measured with conformance signals defined in FC-PI-2 Rev. 10.0 specifications.
2. Measured with PRBS 231-1 at 10-12 BER.

■ **Mechanical Specifications**

# SFP-XCxxHM0xDL40

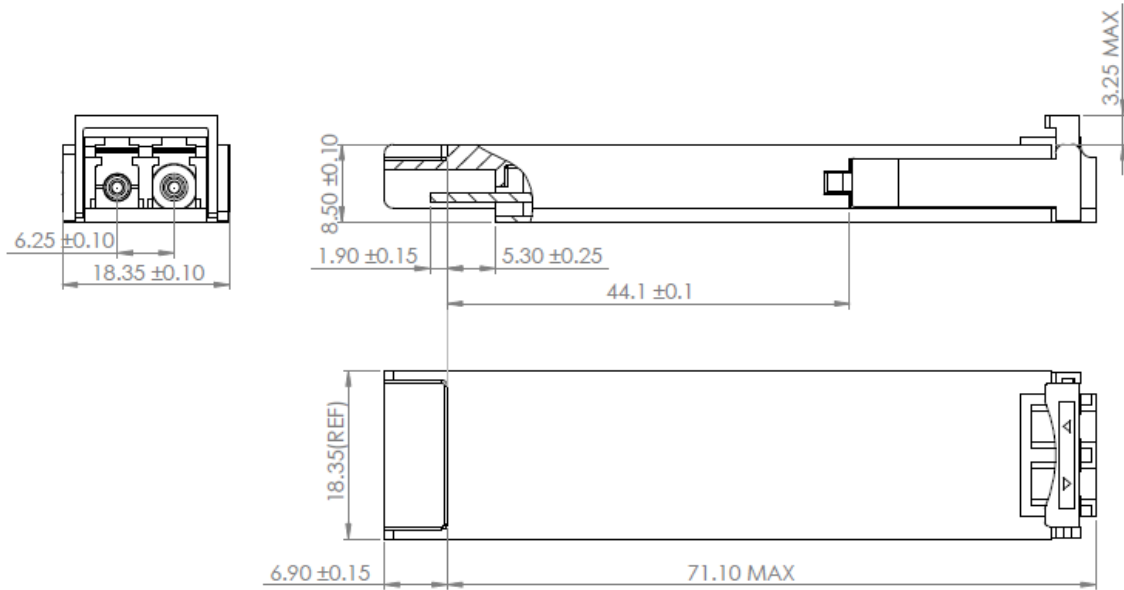

**SFP-XCxxHM0xDL40**

## EEPROM Information

EEPROM memory map specific data field description is as below:

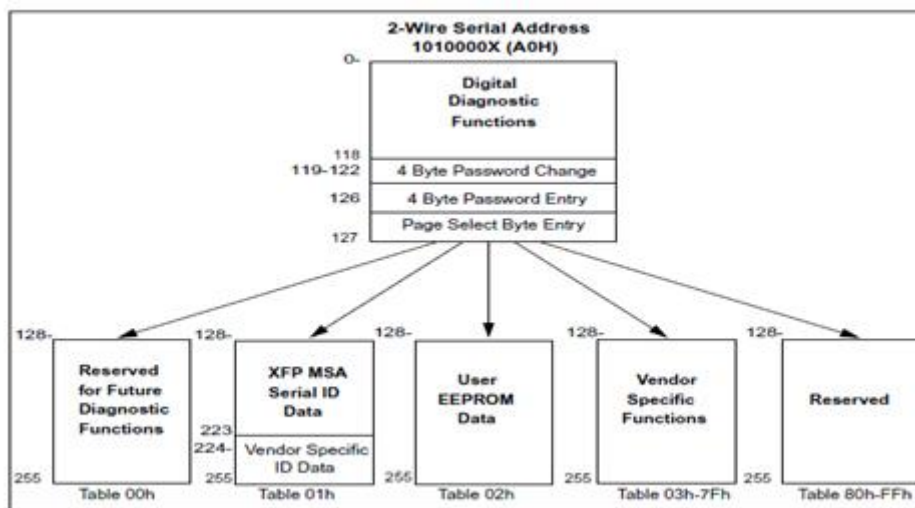

## Digital Diagnostic Monitoring Interface

Five transceiver parameter values are monitored. The following table defines the monitored parameter's accuracy.

**SFP-XCxxHM0xDL40**

Parameter	Range	Accuracy	Calibration
Temperature	0 to +70°C (C)	±3°C	Internal
	0 to +85°C (E)		
	-40 to +85°C (I)		
Voltage	2.97 to 3.63V	±3%	Internal
Bias Current	0 to 100mA	±10%	Internal
TX Power	-1 to 4dBm	±3dB	Internal
RX Power	-16 to -1dBm	±3dB	Internal

### ■ Revision History

Revision	Initiated	Reviewed	Approved	DCN	Release Date
V1.0	xiaoaiyou	wangqiang		New Released.	July 28, 2016